

Derwent
Top 100
Global
Innovator
2020

Susol Super Solution

ANSI VCB

ANSI Vacuum Circuit Breakers



LS ELECTRIC

Susol

Super Solution



Susol VCB



Susol VCB is full line-up new VCB which has the high interrupting capacity, large current (~50kA, ~3000A), and maximized compatibility with existing products through the dual phases and compact sized models.

Contents

• Overview	04
• External structure	20
• Basic features and interrupting operation	22
• Standards and certification	25
• Types and ordering information	26
• Ratings	31
• Accessories	34
• Control circuit diagrams	66
• Dimensions	69
• Technical data	88



Susol VCB

Vacuum Circuit Breaker, VCB is installed in the medium voltage distribution lines to protect life and load equipment. In case of accidents such as over current, short circuit and ground fault current, VCB works by interrupting the circuit through the inner Vacuum Interrupter which is acted by signal from the outside separate relay.

Susol VCB responds.

- customer needs for the breakers with high interrupting capacity and large current due to the integration and increase of the load capacity.
- worldwide trend of diversification in the medium voltage distribution lines.
- increase of the reliability for the temperature characteristics of circuit breakers.

Premium-type products to improve convenience and reliability of medium voltage switchgear configuration.

- full line-up modeling to the high interrupting capacity and large current.
- main structure with high reliability application.
- a variety of accessories and ability to maximize.

Suitable for use as the main circuit breaker to protect key installations in the places such as device industry, power plants, high-rise buildings, large ships.



- ▶ Strengthening of the high interrupting capacity and large current models and full line-up new VCB models to high/middle/low.

Voltage	Interrupting current	Rated current
05/15kV	25/31.5/40/50kA	1200/2000/3000A
27kV	25kA	1200A
38kV	31.5/40kA	1200/2000A

- ▶ Main circuit structure with high reliability.
 - Maximizing the durability and reliability of the main circuit contactors (Stego Tulip contactor).
 - Strong structure for the temperature rise (Natural cooling system).
- ▶ Convenience of switchgear configuration and a variety of accessories.
 - CB compartment structure: Metal isolation structures to prevent the accident spread and ensure safety. And the convenience of switchgear building is extended by its module style.
 - A variety of accessories: UVT, Locking Magnet, Plug Interlock, Key lock, Temperature Sensor, MOC, TOC, Earthing S/W.
 - Maximizing compatibility with existing products through the dualistic deployment of phases and compact models.

※ Type testing is complete for all models according to latest standard, IEEE Std C37.09, IEEE Std C37.20.2, ANSI C37.54, ANSI C37.55, UL (CSA)





Susol VCB Family

Susol VCB series are premium-type products featuring main structure with high reliability application and a variety of accessories and ability to maximize to be suitable for use as the main circuit breaker to protect key installations in the places such as device industry, power plants, high-rise buildings, large ships

4.76/15/27kV (UVL-05/15/27)

- Rated short-time (to withstand current): 4sec
- Rated operating sequence: O-0.3s-CO-15s-CO
- Various cradle: Ha, Hb type
- CB Compartment for MCSG available
- A variety of control power
 - DC 24~30V, DC 48~60V, DC 110V, DC 125V, DC 220V
 - AC 48V, AC 100~130V, AC 220~250V
- A variety of accessories
 - VCB part: Charge switch, UVT, Secondary trip coil, Latch checking switch, Position switch, Locking magnet, Plug interlock, Key lock, Button cover, Button padlock, Padlock (H type Door interlock), MOC
 - Cradle part: MOC (Mechanical Operated Cell switch), TOC (Truck Operated Cell switch), Temperature sensor, Earthing switch & accessories, Door, Door interlock, Door emergency button
 - Others: Racking in/out handle, UVT Time delay controller, CTD (Condensor Trip Device), Temperature module
- Disconnected/Test/Connected Automatic Position Indicator
- Standards and certification
 - IEEE Std C37.09, ANSI C37.54, UL Listed & CSA



Ur (kV)	Isc (kA)	I _r (A)
4.76	25	1200
		2000
15	31.5	1200
		2000
15	25	1200
		2000
27	31.5	1200
		2000
27	25	1200
		2000



Full line – up & Compact

Full line-up new VCB models to the high interrupting capacity and large current (~ 50kA, ~ 3000A) featuring maximization of compatibility with existing products through the dualistic deployment of phases and compact models

4.76/15kV (VH-05/15)

- Rated short-time (to withstand current): 2sec
- Rated operating sequence: O-0.3s-CO-3min-CO
- Various cradle: H type
- CB Compartment for MCSG available
- A variety of control power
 - DC 48V, DC 110V, DC 125V, DC 220~250V
 - AC 48V, AC 110V, AC220V
- A variety of accessories
 - VCB part: Charge switch, UVT, Secondary trip coil, Latch checking switch, Position switch, Locking magnet, Plug interlock, Key lock, Button cover, Button padlock, Padlock (H type Door interlock), MOC
 - Cradle part: MOC (Mechanical Operated Cell switch), TOC (Truck Operated Cell switch), Temperature sensor, Earthing switch & accessories, Door, Door interlock, Door emergency button
 - Others: Racking in/out handle, UVT Time delay controller, CTD (Condensor Trip Device), Temperature module
- Disconnected/Test/Connected Automatic Position Indicator
- Standards and certification
 - IEEE Std C37.09

38kV (UVH-38)

- Rated short-time (to withstand current): 4sec
- Rated operating sequence: O-0.3s-CO-15s-CO
- Various cradle: H type
- CB Compartment for MCSG available
- A variety of control power
 - DC 48V, DC 110V, DC 125V, DC 220~250V
 - AC 48V, AC 110V, AC220V
- A variety of accessories
 - VCB part: Charge switch, UVT, Secondary trip coil, Latch checking switch, Position switch, Locking magnet, Plug interlock, Key lock, Button cover, Button padlock, Padlock (H type Door interlock), MOC
 - Cradle part: MOC (Mechanical Operated Cell switch), TOC (Truck Operated Cell switch), Temperature sensor, Earthing switch & accessories, Door, Door interlock, Door emergency button
 - Others: Racking in/out handle, UVT Time delay controller, CTD (Condensor Trip Device), Temperature module
- Disconnected/Test/Connected Automatic Position Indicator
- Standards and certification
 - IEEE Std C37.09



Ur (kV)	Isc (kA)	Ir (A)
4.76	40	1200
		2000
		3000
	50	1200
		2000
		3000
15	40	1200
		2000
		3000
	50	1200
		2000
		3000



Ur (kV)	Isc (kA)	Ir (A)
38	31.5	1200
		2000
	40	1200
		2000

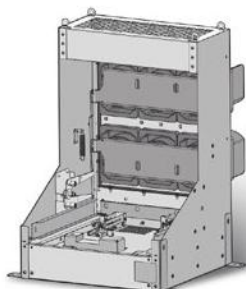

Ha type

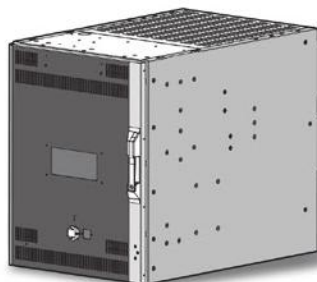

He, Hf type



VH type

Main circuit structure with high reliability

Susol VCB

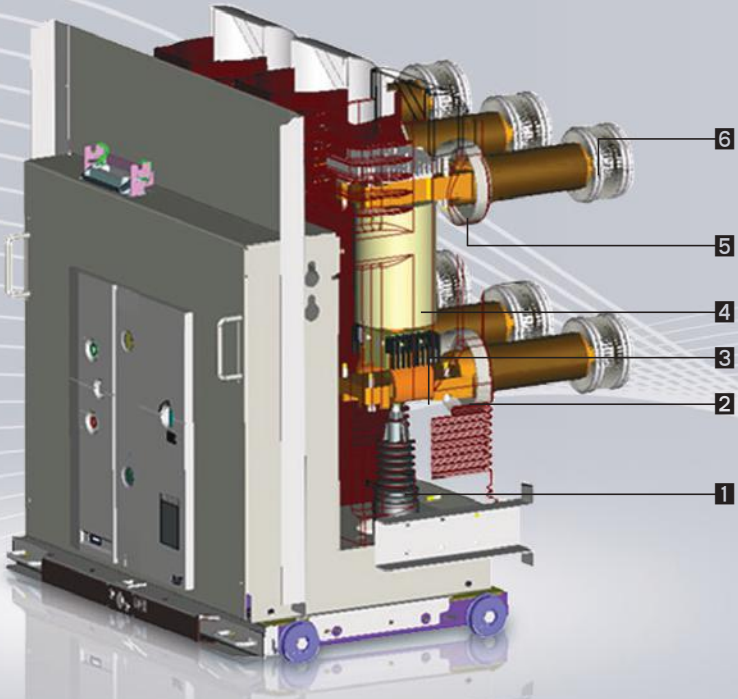

Breaker

- 1 Insulation rod
- 2 Lower terminal
- 3 Shunt
- 4 Vacuum interrupter
- 5 Upper terminal
- 6 Tulip contactor

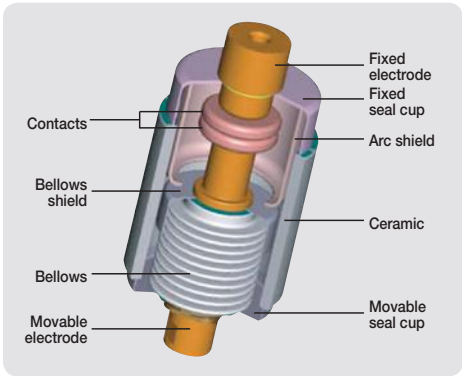

Vacuum Interrupter, VI

The vacuum rate within the VI is very high (approximately 5×10^{-5} Torr) and the spacing between fixed contact and movable contact is about 6~20mm, depending on the voltage. The contacts are in a structure that arc can easily be extinguished and the surfaces of

the contacts are made of special alloy (copper-chromium) and the interior is completely sealed to prevent loss of vacuum. Therefore the wearing of the contacts can be minimized in the event of short-circuit and the arc energy by overvoltage or switching can be reduced effectively.

Convenience and Variety

- Maximizing the durability and reliability of the main circuit contactors (Stego Tulip contactor)
- Strong structure for the temperature rise (Natural cooling system)



Stego Tulip

Main circuit structure with high reliability

- Maximizing the durability and reliability of the main circuit contactors (Stego Tulip contactor)
- Strong structure for the temperature rise (Natural cooling system)

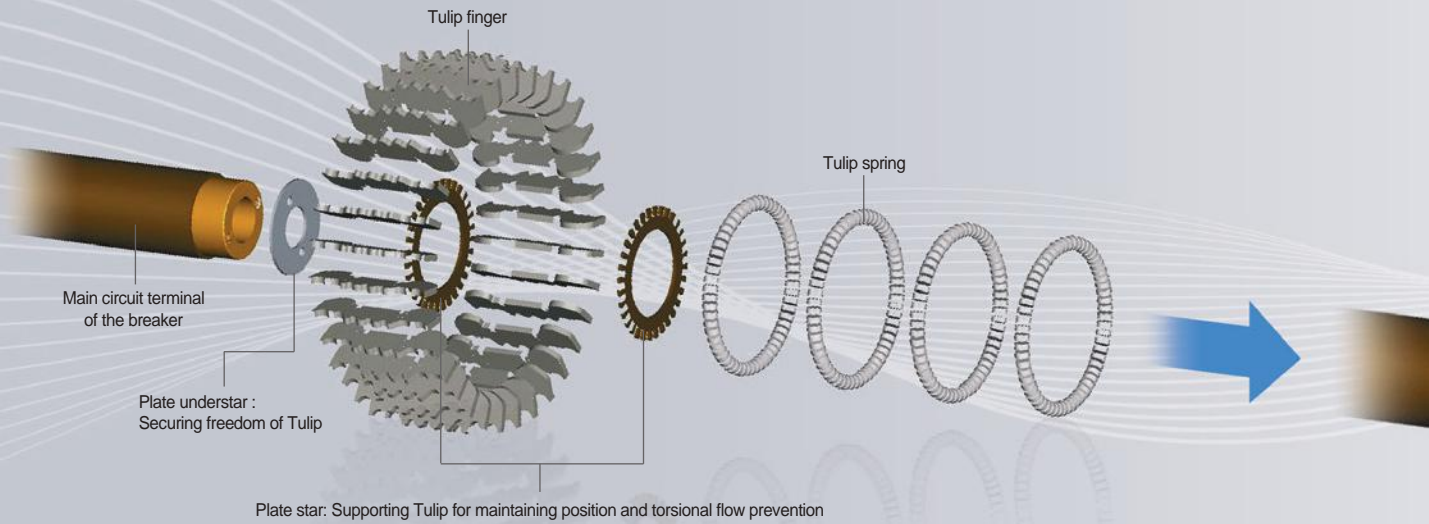

Structure of Stego Tulip Terminal

- Maintaining the connection between breaker and cradle for the optimum current path through securing freedom of Tulip.
- Increasing the heat dissipation area of the contactors and minimizing aging.



4.76/15/27/38kV ...

(UVL-05/15/27, VH-05/15, UVH-38)

- Drawout / natural cooling system
- Improved temperature characteristics and ensured high reliability

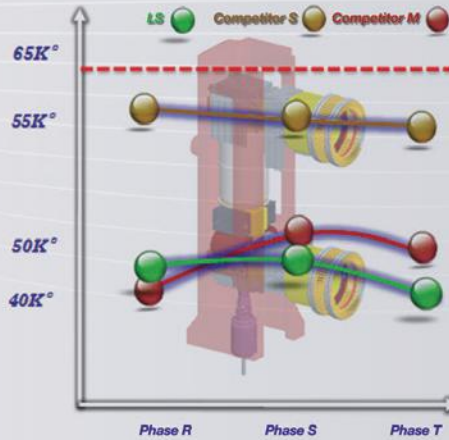

UVL type Tulip contactor



VH Type Tulip contactor



UVH type Tulip contactor

CB Compartment

Convenience in building switchgears

- CB compartment structure: H type cradle
- Metal isolation structure to prevent the accident spread and ensure safety
- Convenience of switchgear building

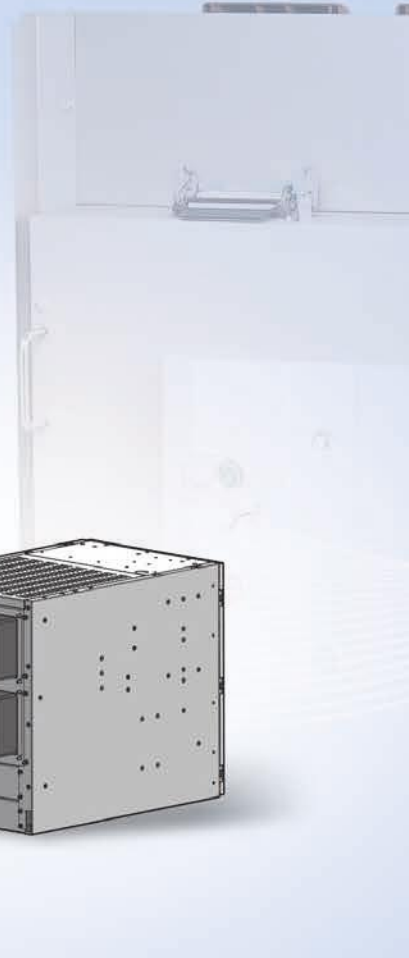
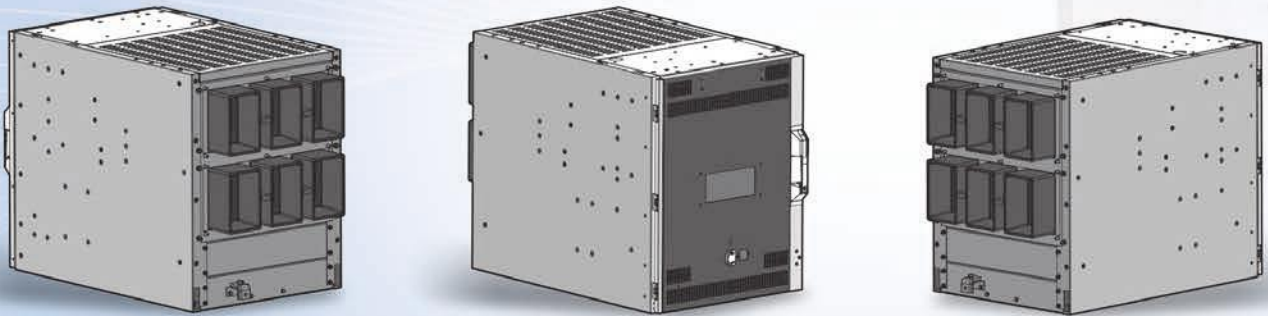

4.76/15/27/38kV 25/31.5/40/50kA

- Metal isolation structure to prevent the accident spread and ensure safety
- Convenience of operation by Truck
 - Drawable in the closed position of the switchgear door
 - Racking-in/out positions indicated mechanically
- Equipped with safety devices and accessories
 - Control power connected Interlock
 - Earthing S/W and interlock, MOC/TOC (ANSI)
- Convenience in building switchgears
 - Module assembly with CB compartment





**CB
Compartment**

**LV
Compartment**

VCB Compartment
5.5kV 31.5kA 1200A

**Busbar & Cable
Compartment**

VT Compartment
5.5kV 31.5kA 1200A

**PT
Compartment**

**Accessories of CB compartment
(H type cradle)**

- MOC (Mechanism Operated Cell S/W)
- TOC (Truck Operated Cell S/W)
- Shutter Padlock
- Temperature Sensor
- Door Emergency ON/OFF Button
- Earthing switch & Accessories
Key lock for Earthing S/W
Locking Magnet for Earthing S/W
Position S/W for Earthing S/W
- TM (Temperature Monitoring Unit)

Accessories

A variety of accessories for UVL-05/15/27

If accessories are attached to the breaker, the function of the breaker is upgraded. Susol VCB provides a variety of accessories depending on the purpose.

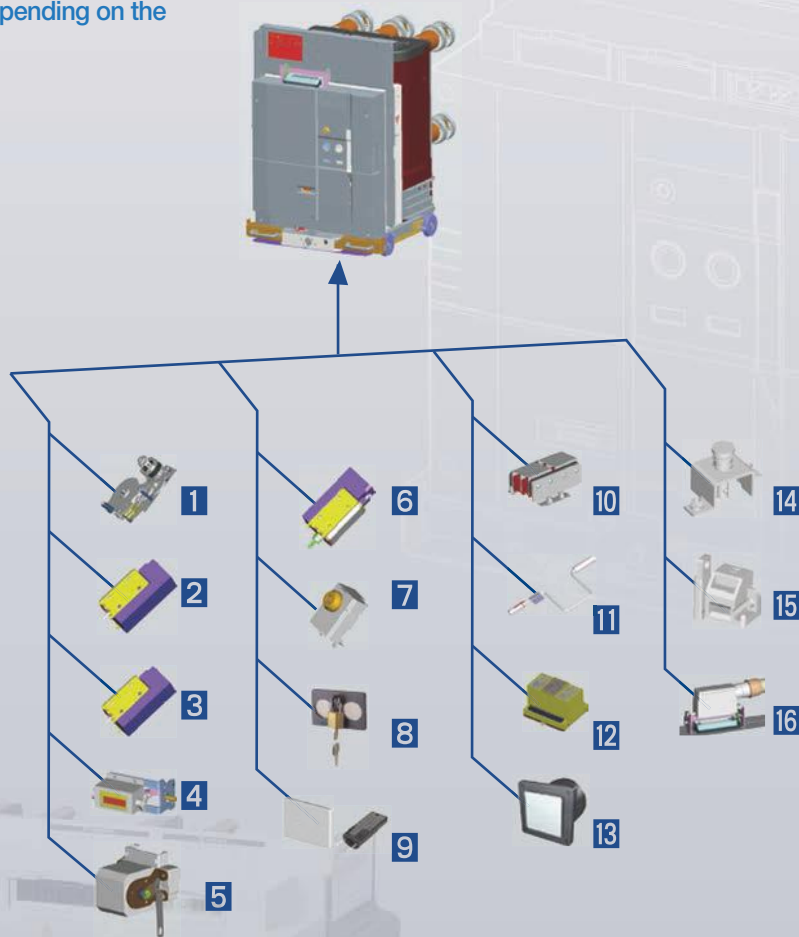

Breaker

- | | | |
|----------------------------|-------------------------------------|---------------------------------------|
| 1 Motor | 7 Key lock | 13 CTD (Condenser trip device) |
| 2 Closing coil | 8 Button padlock | 14 MOC |
| 3 Trip coil | 9 Button cover | 15 Padlock |
| 4 Counter | 10 Position switch | 16 Plug Interlock |
| 5 Auxiliary contact | 11 Racking in/out handle | |
| 6 UVT coil | 12 UVT Time delay controller | |

A variety of accessories for UVCL-05/15/27

If accessories are attached to the cradle, the function of the breaker is upgraded. Susol VCB provides a variety of accessories depending on the purpose.

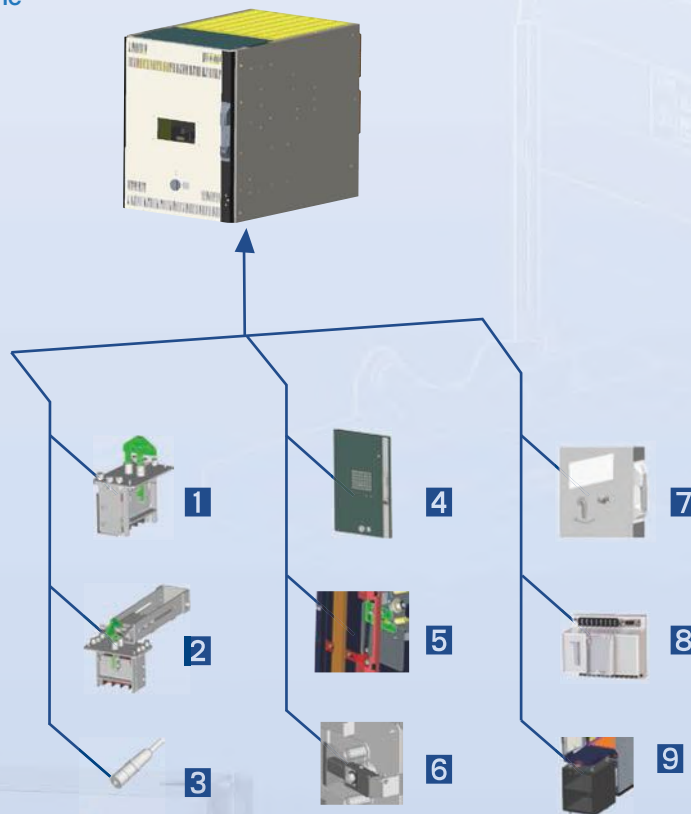

Cradle (H type)

- | | |
|---|---|
| 1 TOC (Truck operated cell s/w) | 6 Shutter padlock |
| 2 MOC (Mechanical operated cell s/w) | 7 Emergency ON/OFF button |
| 3 Temperature sensor | 8 TM (Temperature monitoring unit) |
| 4 Door | 9 Lift Interlock |
| 5 Door interlock | |

Accessories

A variety of accessories for UVH-38

If accessories are attached to the breaker, the function of the breaker is upgraded. Susol VCB provides a variety of accessories depending on the purpose.

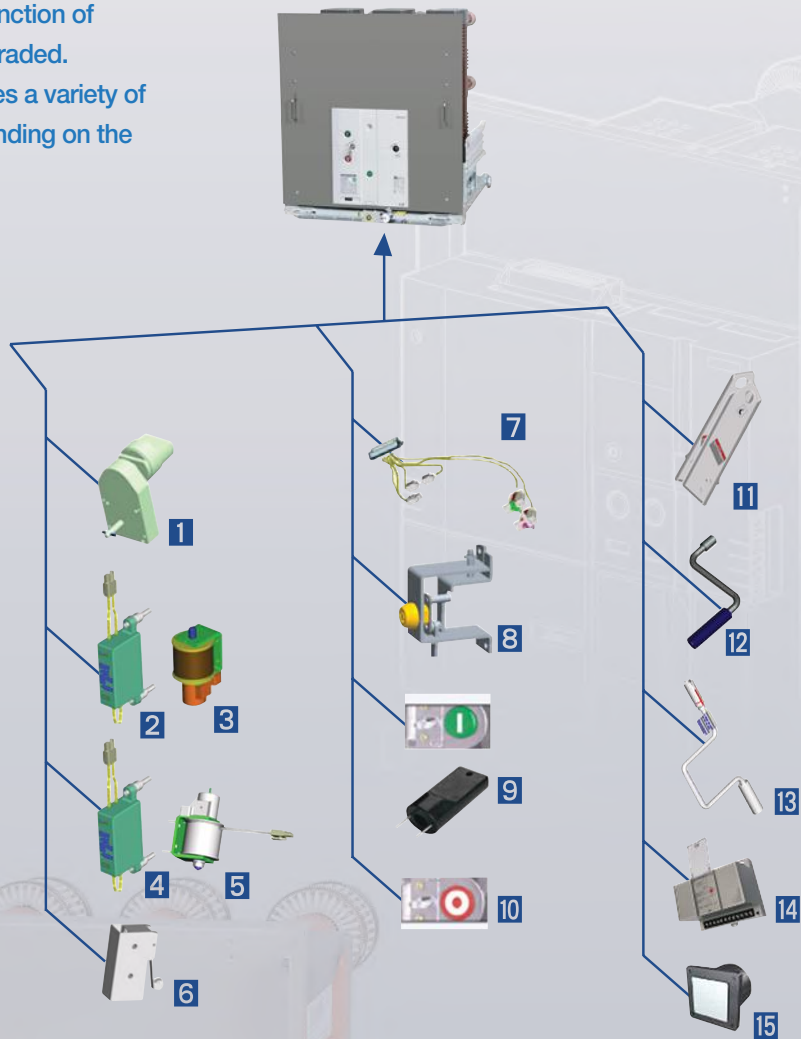

Breaker

- | | | |
|-----------------------------------|---------------------------------|---------------------------------------|
| 1 Motor | 6 Latch checking switch | 12 Charge handle |
| 2 AC/DC coil rectifier | 7 Auxiliary contact wire | 13 Racking in/out handle |
| 3 Trip coil/Closing coil | 8 Key lock | 14 UVT Time delay controller |
| Secondary trip coil | 9 Button cover/Push bar | 15 CTD (Condenser trip device) |
| 4 AC/DC UVT coil rectifier | 10 Button padlock | |
| 5 UVT coil | 11 Lifting hook | |

A variety of accessories for UVCH-38

If accessories are attached to the cradle, the function of the breaker is upgraded. Susol VCB provides a variety of accessories depending on the purpose.

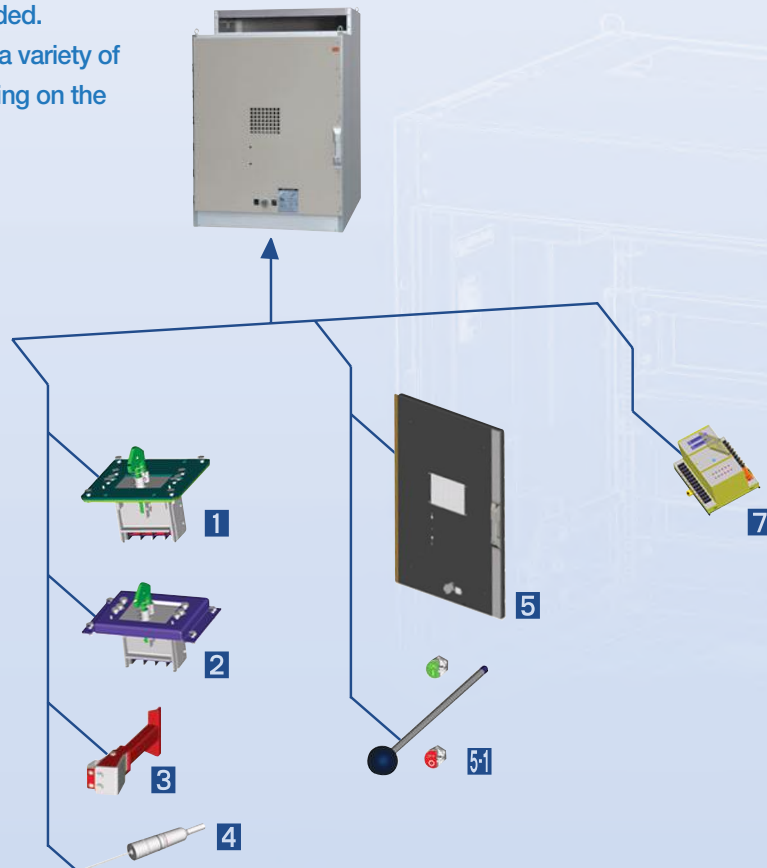

Cradle (H type)

- | | |
|--|------------------------------------|
| 1 MOC (Mechanism operated cell switch) | 5 Door |
| 2 TOC (Truck operated cell switch) | 6 Emergency ON/OFF button |
| 3 Shutter padlock | 7 TM (Temperature monitoring unit) |
| 4 Temperature sensor | |

Accessories

A variety of accessories for VH-05/15

If accessories are attached to the breaker, the function of the breaker is upgraded. Susol VCB provides a variety of accessories depending on the purpose.

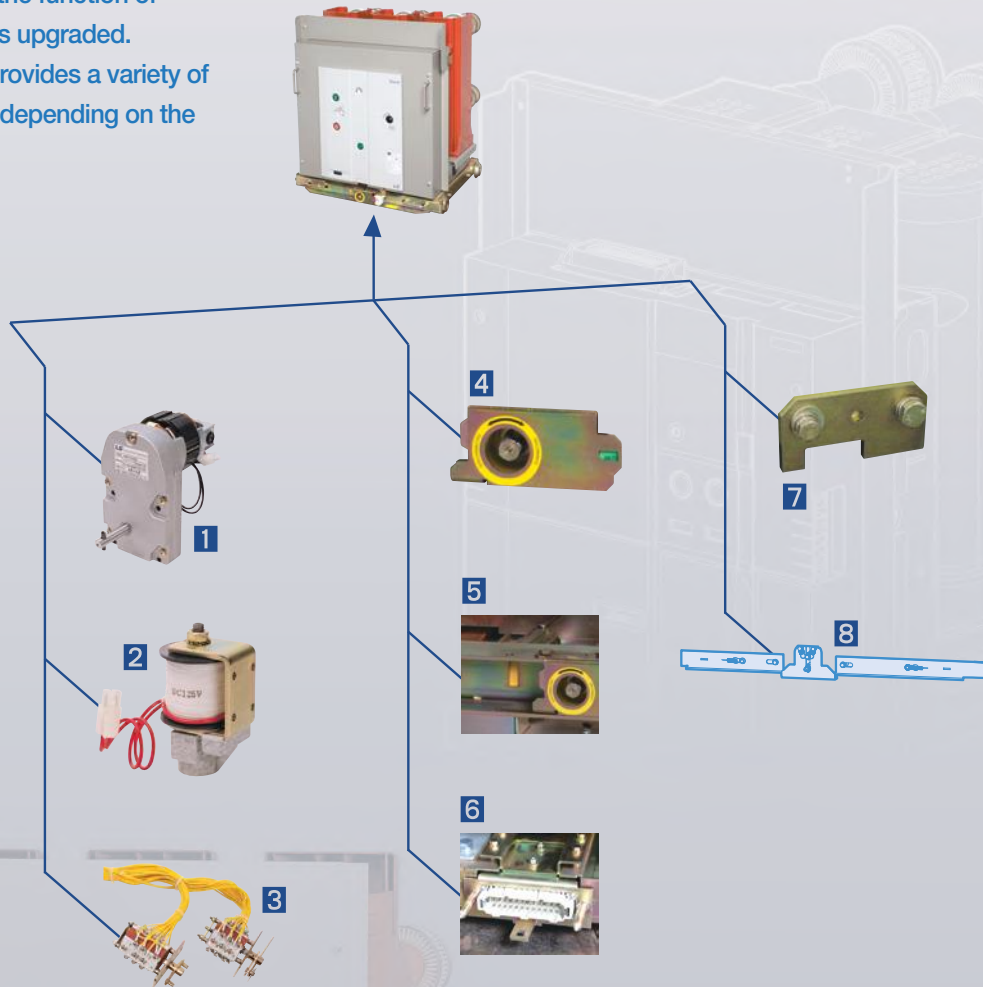

Breaker

- | | |
|--------------------------|---------------------------------|
| 1 Motor | 5 Mechanical position indicator |
| 2 Trip coil/Closing coil | 6 Auto connection |
| 3 Auxiliary Contact | 7 Code plate |
| 4 Position padlock | 8 Charge interlock |

A variety of accessories for VCL-05/15

If accessories are attached to the cradle, the function of the breaker is upgraded. Susol VCB provides a variety of accessories depending on the purpose.

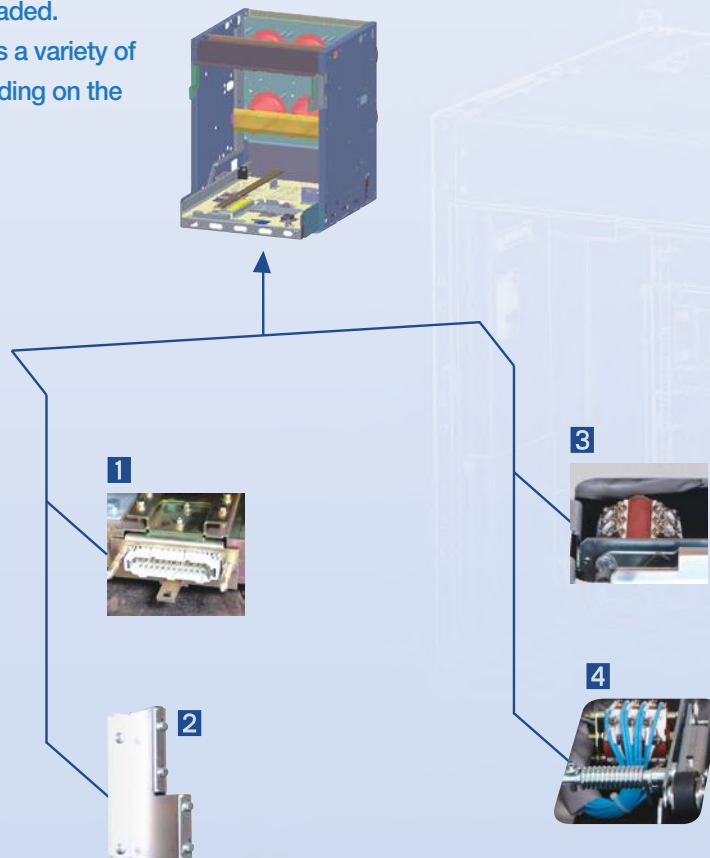

Cradle (H type)

- 1 Auto connection
- 2 Charge interlock
- 3 Mechanically operated cell switch (MOC)
- 4 Truck operated cell switch (TOC)

External structure of VCB

Susol

Breaker ... UVL type



Name of each part

- 1 CLOSE Button
- 2 OPEN Button
- 3 Charge/Discharge Indicator
- 4 CLOSED/OPEN Indicator
- 5 Manual Charging Handle
- 6 Operation Counter
- 7 3 Position Indicator
(Disconnected, Test, Connected)

Back side



Breaker ... UVH type



Name of each part

- ① CLOSE Button
- ② OPEN Button
- ③ Charge/Discharge Indicator
- ④ CLOSED/OPEN Indicator
- ⑤ Manual Charging Handle
- ⑥ Key Lock
- ⑦ Operation Counter
- ⑧ 3 Position Indicator
(Disconnected, Test, Connected)

Back side



Basic functions and interrupting operation

Susol

Basic functions

Manual operation

① Manual Charge

- UVL type: operate the charge handle 7-8 times as a fully stroke.
- UVH type: Insert the charge handle into the handle slot first. Rotate the handle clockwise 40 times more and then charge will be complete with a click sound.
 - When the closing spring is charged fully "CHARGED" is displayed at the charge indicator.

② Manual closing

- Pressing the CLOSE Button the breaker is closed.
- With the closing of the breaker "CLOSE" is displayed at CLOSED/OPEN Indicator and "DISCHARGED" at the charge indicator.

③ Manual trip

- Pressing the OPEN Button the breaker is opened.
- "OPEN" is displayed at CLOSED/OPEN Indicator.

Electric operation

① Electric charge

The breaker is remotely closing with charging of closing spring.
If the breaker trips the closing spring is automatically charged by gear motors.

② Electric closing

Remote closing is operated by the closing coil.

③ Electric trip

Remote trip can be operated by the trip coil or UVT coil.

Main contacts are operated by the energy of the spring mechanism and closing spring is charged by the motor in the mechanism.

Breaker is closed by closing coil and tripped by trip coil.

These operations are repeated in VCB as shown in the below sequence chart.

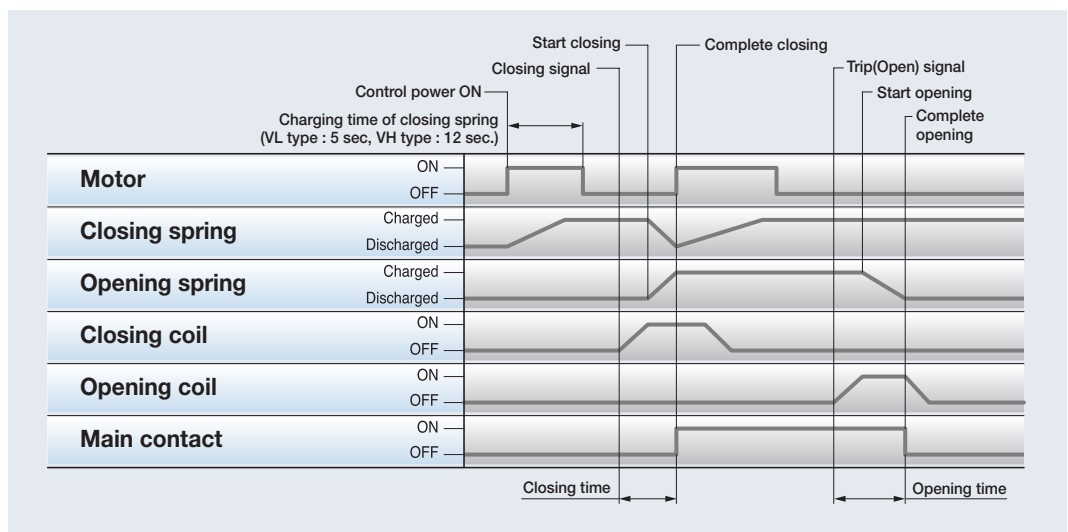

Sequence of the switching mechanism

The interruption of vacuum interrupters

The interruption of VCB is carried out by the vacuum interrupters. Interrupter contacts as a key part made of copper - chromium (CuCr) material with spiral shape have low contact wear characteristics and withstand voltage is excellent. Spiral contacts make the arc generated between the surfaces of contacts rotated around the surface of contact by the induced magnetic field generated due to the spiral contact structure, which results in preventing local heating, thereby corruption and interrupting instantaneously.

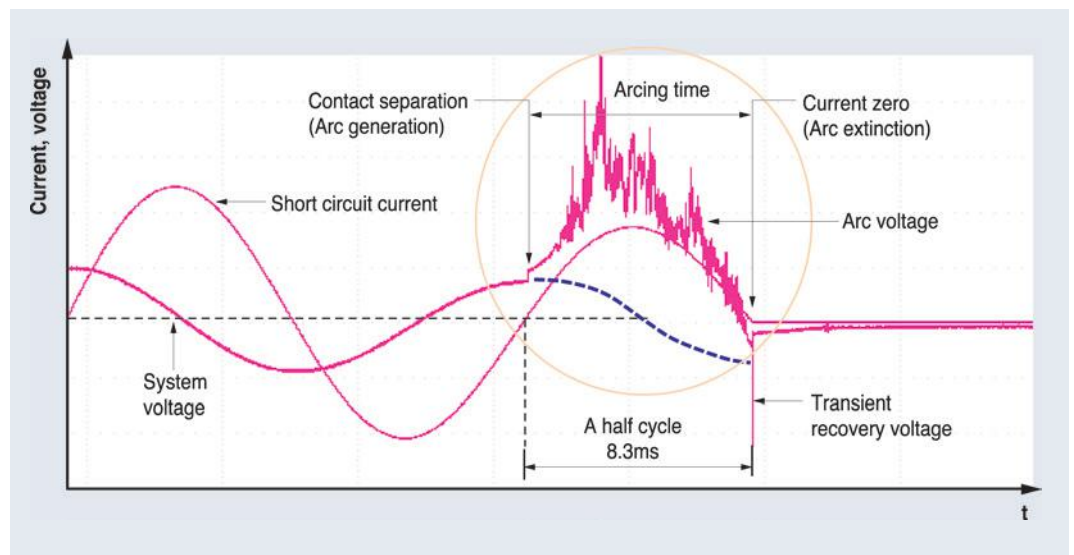
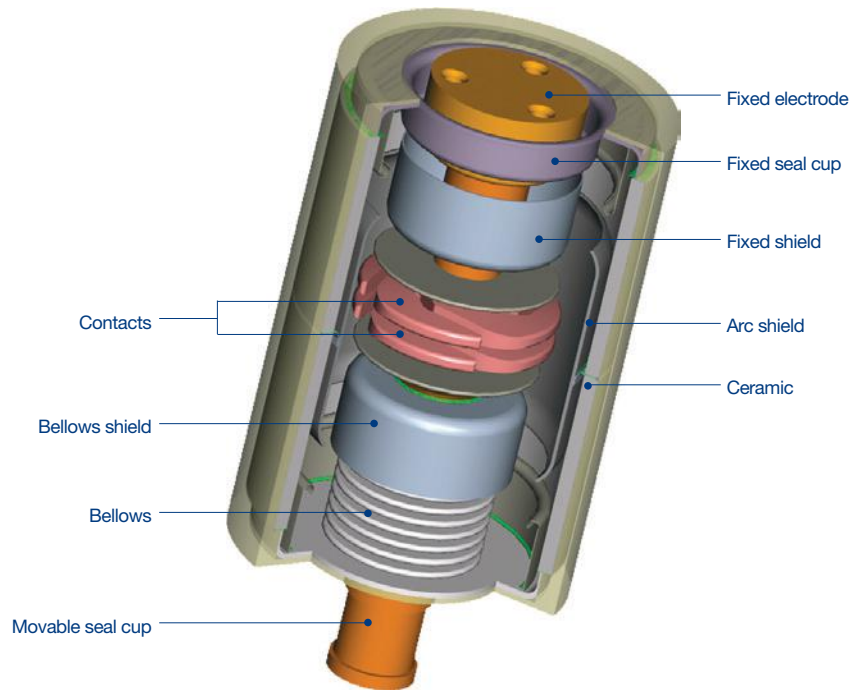

An example of oscillogram obtained through the interrupting test using LC resonant circuit

Basic functions and interrupting operation

Susol

The interruption of vacuum interrupters

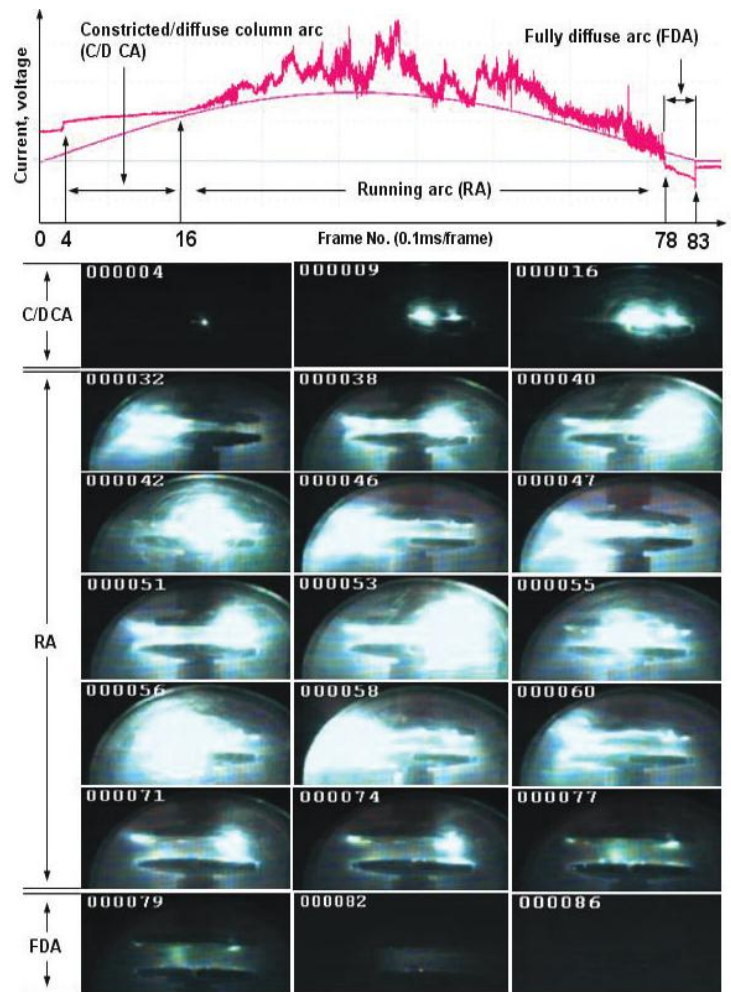

Arc voltage waveforms and arc image captured during arcing time

In case of using the flat contact any of the designs do not reflect on when contacts are opening the arc with high temperature is contracted and fixed in the center of the contacts, which is called pinch effect. To prevent the effect two kinds of contact shapes are designed. One is Axial magnetic field which spreads the arc before its contraction, and the other is Radial magnetic field which permits the contraction of the arc but makes it rotated to disperse the energy. Because contracted arc is shaped like a cylinder it is called Contracted arc or columnar arc.

Spiral contact structure (Radial magnetic field), using the force ($F = j \times B$) generated by the interaction of the radial magnetic field caused by the current flowing through the arc between two contacts, disperse the arc energy evenly on the surface of contact by rotating the arc that is contracted by the pinch effect so as to minimize contact damage. The images show arc behavior during the arcing time of about 8ms by shooting with high-speed camera capable of shooting 10,000 frames per sec. (0.1ms/frame) by focusing on parts of the arcing time on the above graph and simultaneously measured arc voltage also represented to show arc state by section.

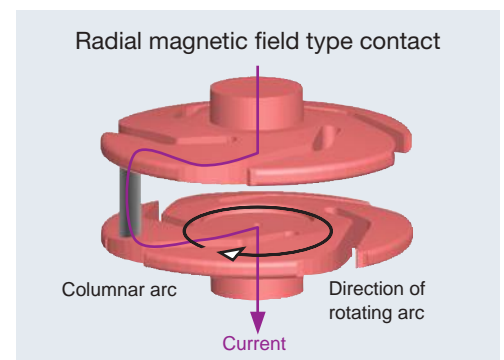

Arc driving principle in the contacts of Radial magnetic field

Standards and certification

Susol

Susol VCB has been type tested and obtained certifications according to the latest IEC standard at international testing laboratory and can be installed and applied at the environment and conditions in accordance with the standard.

- **Standard**
 - IEEE Std C37.09, ANSI C37.54, UL Listed & CSA
- **Test and certification**
 - Test report (KERI)
 - Test report (KEMA)

The image displays three overlapping copies of a UL Certificate of Compliance. The most prominent one in the center contains the following information:

CERTIFICATE OF COMPLIANCE

Certificate Number: 20141230-E468323
 Report Reference: E468323-20141227
 Issue Date: 2014-DECEMBER-30

Issued to:
 LSIS CO LTD
 CHEONG JU PLANT
 1 SONG JUNG-DONG, HUNG DUK-KU
 CHEONG JU-SHI CHUNG CHEONG BUG
 KOREA

This is to certify that representative samples of CIRCUIT BREAKERS AND METAL-CLAD OVER 1000 VOLTS Refer addendum page

Have been investigated by UL in accordance with the Standard(s) indicated on this Certificate.

Standard(s) for Safety: ANSI C37.54-2002-Indoor Alternating-Current Voltage Circuit Breakers Applied as Removable Elements in Metal-Enclosed Switchgear Assemblies - Test Procedures and CAN/CSA-C22.2 No. 31-14-Switchgear Assemblies

Additional Information: See the UL Online Certifications Directory at www.ul.com/database for additional information

Only those products bearing the UL Certification Mark should be considered as being covered by UL's Certification and Follow-Up Service.

Recognized components are incomplete in certain constructional features or restricted in performance capabilities and are intended for use as components of complete equipment submitted for investigation rather than for direct separate installation in the field. The final acceptance of the component is dependent upon its installation and use in complete equipment submitted to UL LLC.

Look for the UL Certification Mark on the product.

Susol
 Susol (Korea), Susol (China), Susol (Japan) and Susol (USA)
 No. 1234
 Any information and documentation regarding UL Mark services are provided at www.ul.com or any authorized branch of UL. The position, place, and name of the Customer Service Representative is www.ul.com/customer

Page 1 of 2

Standard(s) for Safety: ANS/NEMA C37.55-2002 -Medium Voltage Metal-Clad Assemblies - Conformance Test Procedures, ANS/NEMA C37.54-2002-Indoor Alternating-Current Medium-Voltage Circuit Breakers Applied as Removable Elements in Metal-Enclosed Switchgear Assemblies - Conformance Test Procedures and CAN/CSA-C22.2 No. 31-14-Switchgear Assemblies

Additional Information: See the UL Online Certifications Directory at www.ul.com/database for additional information

Only those products bearing the UL Certification Mark should be considered as being covered by UL's Certification and Follow-Up Service.

Look for the UL Certification Mark on the product.

Susol
 Susol (Korea), Susol (China), Susol (Japan) and Susol (USA)
 No. 1234
 Any information and documentation regarding UL Mark services are provided at www.ul.com or any authorized branch of UL. The position, place, and name of the Customer Service Representative is www.ul.com/customer

Page 1 of 2

Standard(s) for Safety: "See Addendum page"

Additional Information: See the UL Online Certifications Directory at www.ul.com/database for additional information

Only those products bearing the UL Certification Mark should be considered as being covered by UL's Certification and Follow-Up Service.

Recognized components are incomplete in certain constructional features or restricted in performance capabilities and are intended for use as components of complete equipment submitted for investigation rather than for direct separate installation in the field. The final acceptance of the component is dependent upon its installation and use in complete equipment submitted to UL LLC.

Look for the UL Certification Mark on the product.

Susol
 Susol (Korea), Susol (China), Susol (Japan) and Susol (USA)
 No. 1234
 Any information and documentation regarding UL Mark services are provided at www.ul.com or any authorized branch of UL. The position, place, and name of the Customer Service Representative is www.ul.com/customer

Page 1 of 2

Types and ordering information

Susol

UVL-05/15/27

Breaker

UVL	15	H	32	A	12
Basic model name	Rated voltage (kV)	Version	Interrupting current (kA)	Phase distance/Compatibility	Rated current (A)
UVL Susol VCB	05 4.76 15 15 27 27	P Fixed H H type drawout (for MCSG)	25 25 32 31.5	A 150mm B 210mm C 254mm D 275mm R 150mm (Compact MCSG) S 210mm (Compact MCSG)&CI	12 1200A 20 2000A

P type
- 4.76/15kV 25/31.5kA 1200/2000A (Phase 150/210/254)
- 27kV 25kA 1200A (Phase 254)

H type
- 4.76/15kV 25/31.5kA 1200A (Phase 150/210)
- 4.76/15kV 25/31.5kA 2000A (Phase 210)
- 4.76/15kV 25/31.5kA 1200A (Phase 150/210, Compact MCSG)
- 4.76/15kV 25/31.5kA 2000A (Phase 210, CI)

UVL-15H32A12	M1	C1	T1	SB2	U1	A	13...
	Motor control voltage		Trip coil voltage		UVT	Other accessories ^{Note)}	
	M0 Without motor M1 DC 110V M2 DC 200~250V M3 DC 125V M4 DC 24V~30V M5 AC 48V~60V M6 AC 48V M7 AC 100V~130V M8 AC 200V~250V		T0 Without trip coil T1 DC 110V T2 DC 200~250V T3 DC 125V T4 DC 24V~30V T5 AC 48V~60V T6 AC 48V T7 AC 100V~130V T8 AC 200V~250V		U0 Without UVT U1 DC 110V U2 DC 200~250V U3 DC 125V U4 DC 24V~30V U5 AC 48V~60V U6 AC 48V U7 AC 100V~130V U8 AC 200V~250V	A1 Secondary Trip coil A2 Secondary Trip Coil with TCS Contact A3 Position s/w (Test: 1a1b, Service: 2b) A4 Position s/w (Test: 2a, Service: 2a) A5 Position s/w (Test: 1a1b, Service: 1a1b) A7 Keylock A8 Button Padlock A9 Button cover AA Lead Wire AB User Plug (Part) AC Plug Interlock AD Padlock (H type) AE MOC AI Mecha Shaft Interlock Lever AL Energy Release AM Keylock (KirkKey, CAMLOCK type) AN Keylock (KirkKey, CN22 type) AP Keylock (KirkKey, Double CAMLOCK type) AV CT operated coil 1A AW CT operated coil 5A AX Button Padlock In Open	

Note) UVT is only applicable for Fixed type (P Type)

Note)

- In case of selecting accessories such as A1(Secondary coil), A4(position S/W 2a2a), A7(key lock), A147 is type name in the ordering.
- Unable to select A1(Secondary Trip Coil),U1~U8(UVT) simultaneously.
- A3(Position S/W 1a3b), A4(Position S/W 2a2b) and A5(Position S/W 2a2b) can not be selected simultaneously.
- A1(Secondary Trip Coil) and A2(Secondary Trip Coil with TCS Contact) can not be selected simultaneously.
- A8(Button Padlock) and A9(Button Cover), AP(Button Padlock In Open) can not be selected simultaneously.
- A7(Keylock), AM(KirkKey, CAMLOCK Type), AN(KirkKey, CN22 type),AX(Double Keylock) can not be selected simultaneously.
- When A1(Secondary Trip Coil) is selected the maximum available auxiliary contacts are 9a9b.
- When A2(Secondary Trip Coil with TCS Contact) is selected the maximum available auxiliary contacts are 4a3b, 9a8b.
- H type breaker includes options such as AC(Plug Interlock), AD(Padlock(H type)), AE(MOC) as standard.
- AI (Mecha Shaft Interlock Lever) is available only for 12kV, P type

Closing coil voltage	Connector and wire
C0 Without closing coil C1 DC 110V C2 DC 200~250V C3 DC 125V C4 DC 24V~30V C5 DC 48V~60V C6 AC 48V C7 AC 100V~130V C8 AC 200V~250V	SA2 Standard A type connector, 4a4b SA4 A type connector, 10a10b SB2 B type connector, 4a4b SA4 B type connector, 10a10b

Cradle

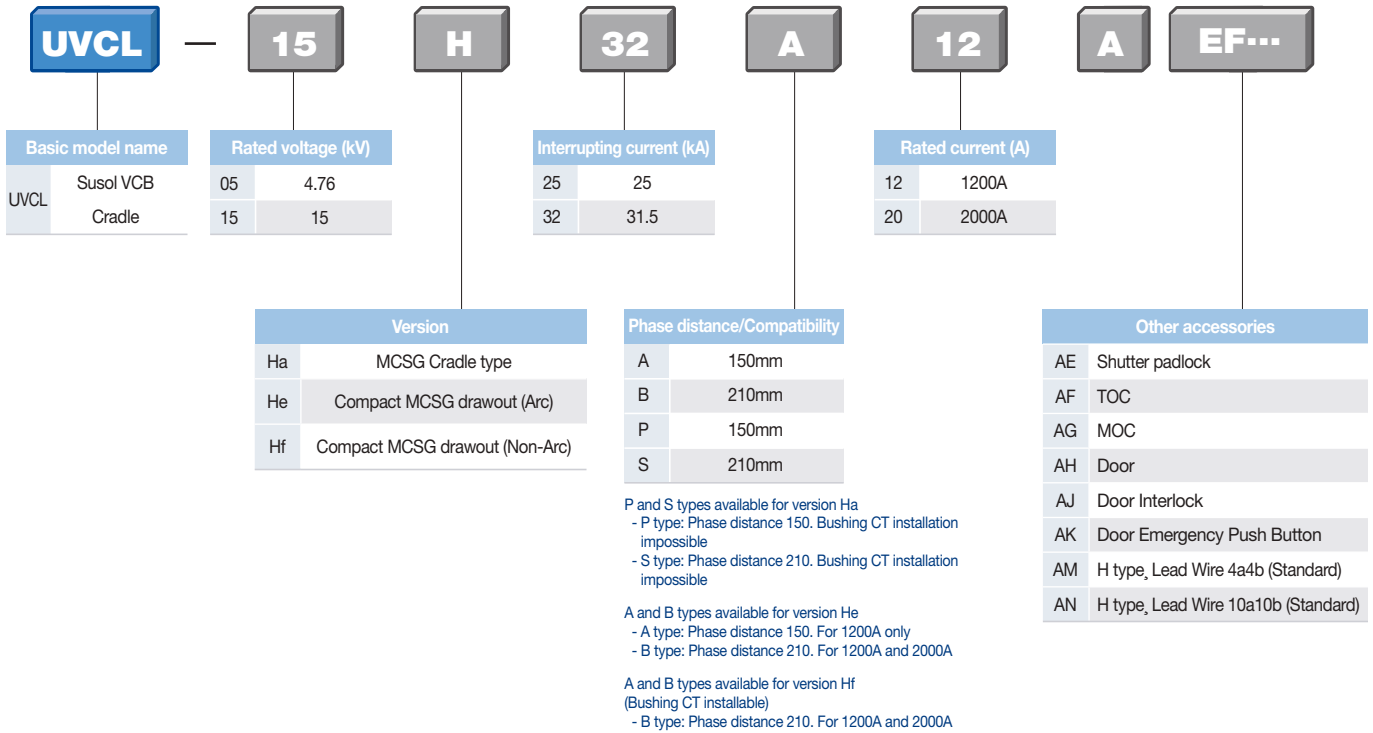

- Note) 1. Ha type cradle cannot use a door and door options. You can use a door for He, Hf type cradle only.
 2. AJ and AK can not be selected without door(AH).
 3. TM(Temperature Monitoring) should be used with AL(Temperature Sensor).
 4. H type lead wire(AM, AN) is required for cradle in case of using H type breaker.
 5. If H type breaker options A8 (Button Padlock) and A9 (Button Cover), AP(Button Padlock In Open) are selected the cradle option AK (Door Emergency Push Button) is not available.
 6. H type breaker includes options such as AE(Shutter padlock), AE(TOC), AG(MOC), AH(Door), AJ(Door Interlock) as standard.

Types and ordering information

Susol

UVH-38

Breaker

UVH	38	H	32	E	12
Basic model name	Rated voltage (kV)	Version	Interrupting current (kA)	Phase distance/Compatibility	Rated current (A)
UVH Susol VCB	38 38	P Fixed H H type drawout (for MCSG)	32 31.5 40 40	E 300mm	12 1200A 20 2000A

UVH-38H32E12	M1	C1	T1	SB2	U1	A	16...
	Motor control voltage		Trip coil voltage		UVT		
	M0 Without motor M1 DC 110V M2 DC 220~250V M3 DC 125V M5 DC 48V M6 AC 48V M7 AC 110V M8 AC 220V		T0 Without trip coil T1 DC 110V T2 DC 220~250V T3 DC 125V T5 DC 48V T6 AC 48V T7 AC 110V T8 AC 220V		U0 Without UVT U1 DC 110V U2 DC 220~250V U3 DC 125V U5 DC 48V U6 AC 48V U7 AC 110V U8 AC 220V		
		Closing coil voltage		Connector and wire		Other accessories	
		C0 Without closing coil C1 DC 110V C2 DC 220V~250V C3 DC 125V C5 DC 48V C6 AC 48V C7 AC 110V C8 AC 220V		SA2 Standard A type connector, 4a4b SA4 Standard A type connector, 10a10b SB2 Standard B type connector, 4a4b SB4 Standard B type connector, 10a10b SC2 Standard AutoCon. connector, 4a4b SC4 Standard AutoCon. connector, 10a10b		A1 Secondary Trip coil A2 Secondary Trip Coil with TCS Contact A6 Latch checking s/w A7 Keylock A8 Button padlock A9 Button cover AA Lead Wire AB User Plug(Part) AE MOC	
				1. H type is for SC2 and SC4 only. (Auto connection type) 2. P type corresponds to both SA and SB type			

Note) UVT is only applicable for Fixed type (P type)

Note)

- In case of selecting accessories such as A1(Secondary coil), A7(key lock), A8(Button Padlock) A178 is type name in the ordering.
- Unable to select A1(Secondary Trip Coil),U1~U8(UVT) simultaneously.
- A1(Secondary Trip Coil) and A2(Secondary Trip Coil with TCS Contact) can not be selected simultaneously.
- A8(Button Padlock) and A9(Button Cover) can not be selected simultaneously.
- When A2(Secondary Trip Coil with TCS Contact) is selected the maximum available auxiliary contacts are 4a3b, 9a9b.
- H type breaker includes options such as AE(MOC) as standard.
- In case of selecting UVT A6 (Latch checking S/W) is not allowed. A6 (Latch checking S/W) is installed by default to make electrical interlock with UVT.

Optional	
CTD1	Condenser Trip Device (AC110V)
CTD2	Condenser Trip Device (AC220V)
UDC1	UVT Time Delay Controller (ADC110V)
UDC2	UVT Time Delay Controller (ADC220V)
UDC3	UVT Time Delay Controller (ADC48V)
CTU	Coil Test Unit

Cradle

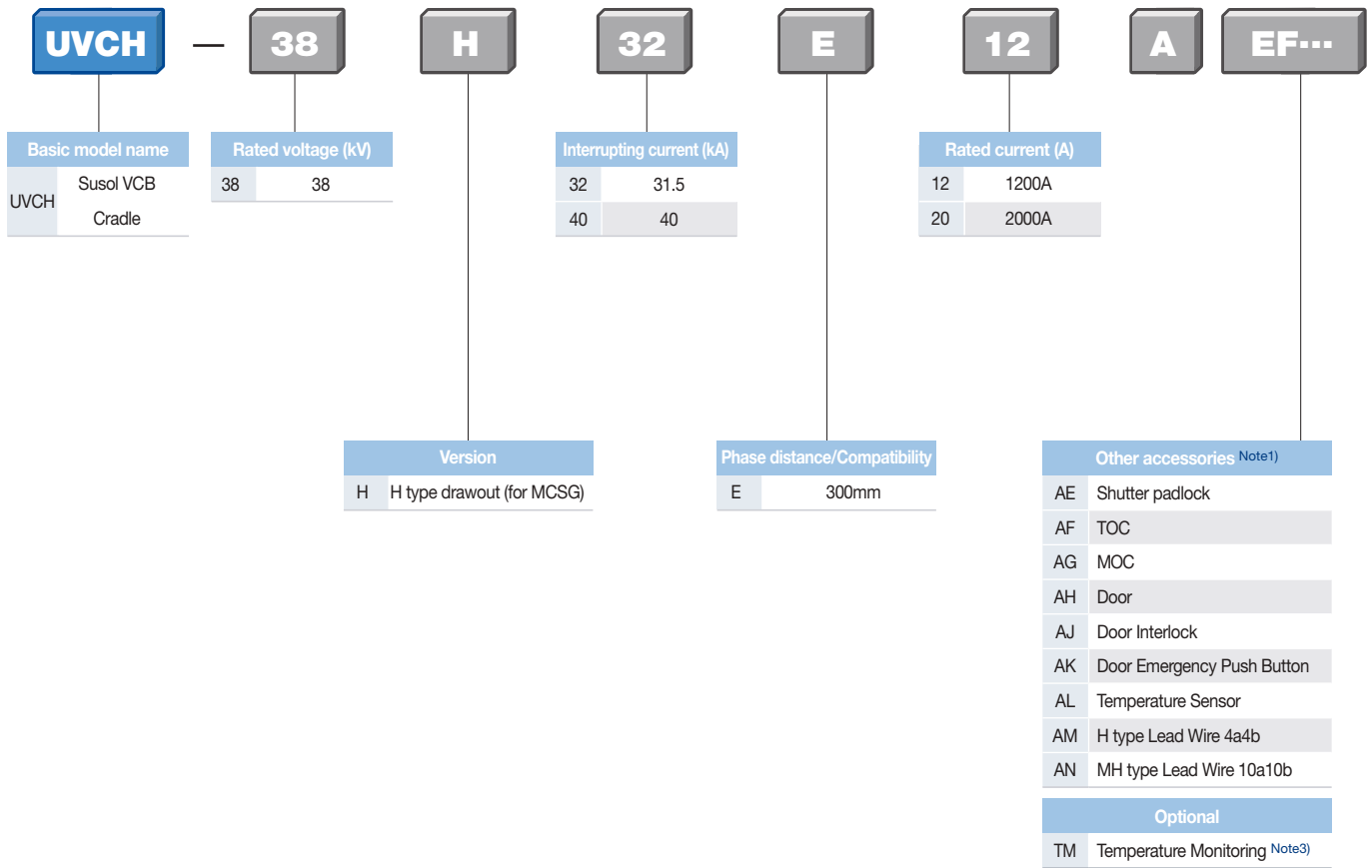

Note) 1. AJ and AK can not be selected without door (AH).
 2. TM (Temperature Monitoring) should be used with AL (Temperature Sensor).
 3. H type lead wire - one of AM, AN is required for cradle in case of H type breaker.
 4. If H type breaker options A8 (Button Padlock) and A9 (Button Cover) are selected the cradle option AK (Door Emergency Push Button) is not available.
 5. H type breaker includes options such as AE (Shutter padlock), AE (TOC, AG (MOC), AH (Door), AJ (Door Interlock) as standard.

Types and ordering information

Susol

VH-05/15

Breaker

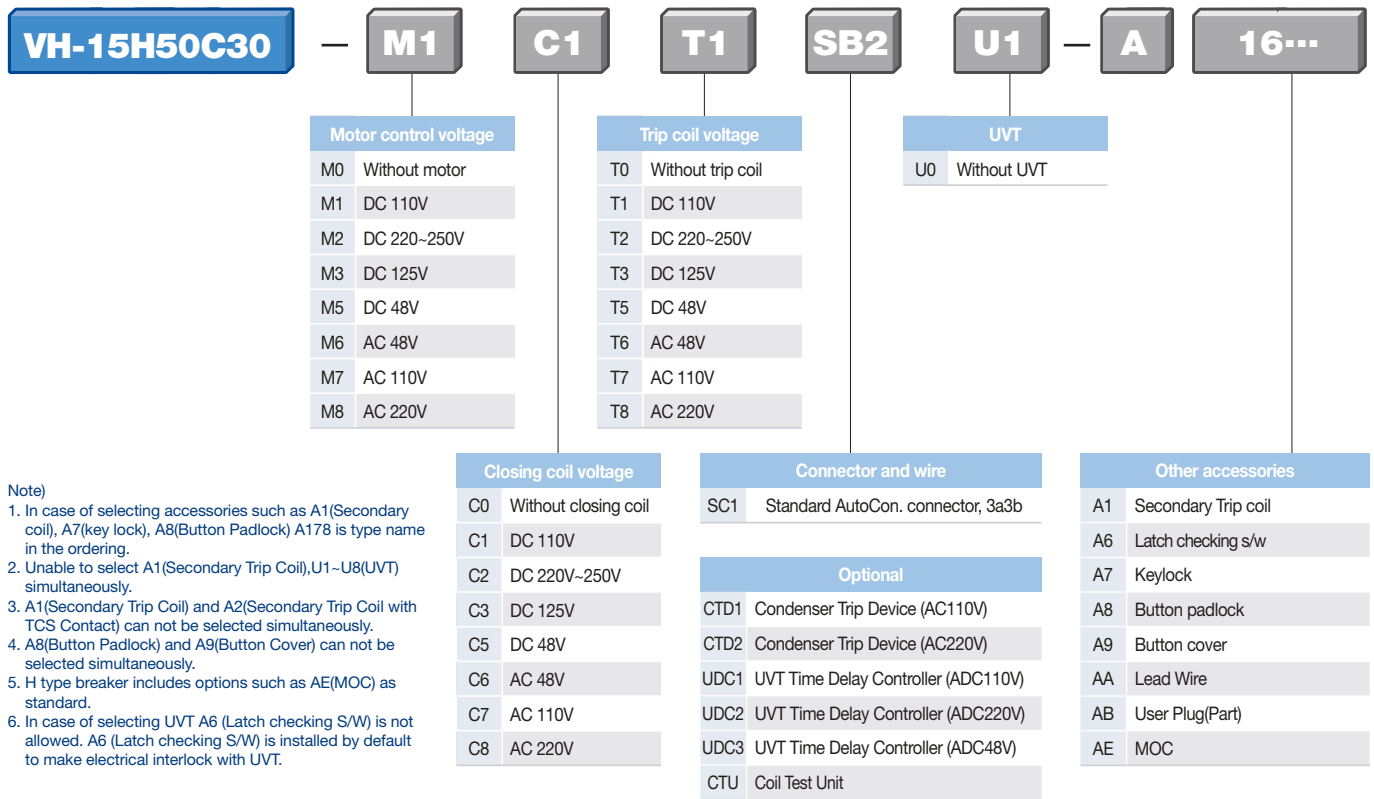
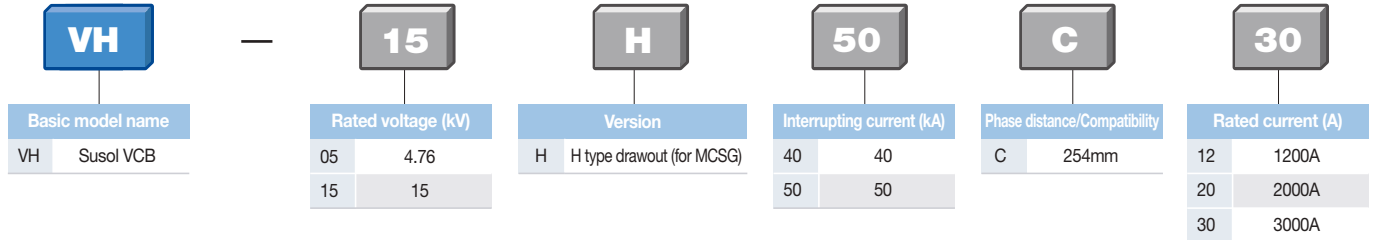

Note)

- In case of selecting accessories such as A1(Secondary Trip coil), A7(key lock), A8(Button Padlock) A178 is type name in the ordering.
- Unable to select A1(Secondary Trip Coil),U1-U8(UVT) simultaneously.
- A1(Secondary Trip Coil) and A2(Secondary Trip Coil with TCS Contact) can not be selected simultaneously.
- A8(Button Padlock) and A9(Button Cover) can not be selected simultaneously.
- H type breaker includes options such as AE(MOC) as standard.
- In case of selecting UVT A6 (Latch checking S/W) is not allowed. A6 (Latch checking S/W) is installed by default to make electrical interlock with UVT.

Cradle

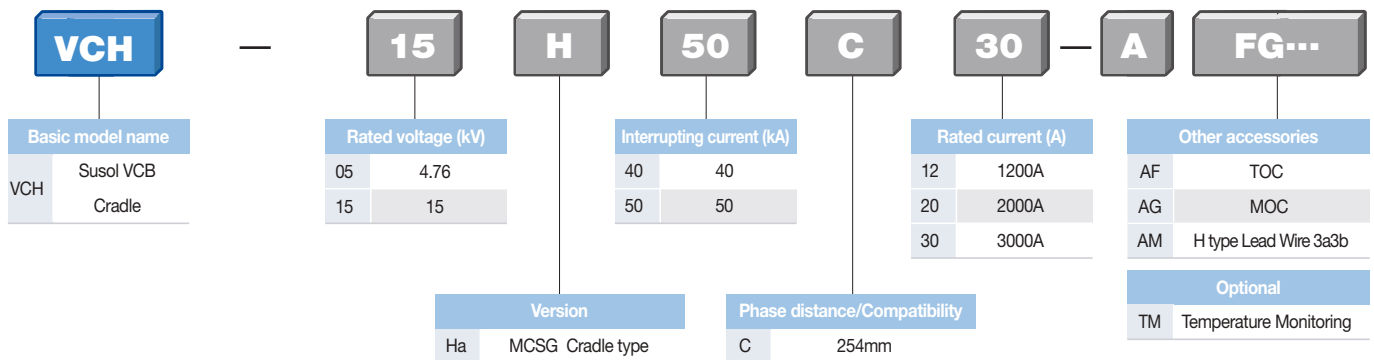

Ratings - 4.76/15/27kV 25/31.5kA 1200/2000A

Susol

UVL-05/15/27



Item		UVL-05□25,32□12,20						UVL-15□25,32□12,20						UVL-27□25□12	
Rated maximum voltage	(kV)	4.76						15						27	
Rated continuous current	(A)	1200			2000			1200			2000			1200	
Rated power frequency	(Hz)	50/60													
Power frequency withstand voltage	(kA)	19						36						60	
Full wave lightning impulse withstand voltage	(kA)	60						95						125	
Rated short-time current	r.m.s.	25/31.5						25						25	
	Peak	65/81.9						65						65	
Short-time current duration	(sec)	4													
Rated short-circuit current	Breaking	25/31.5						25						25	
	Making	65/81.9						65						65	
Rated interrupting capacity	(MVA)	207/260						650/820						1170	
Rated Interrupting time	(cycle)	3													
Standard operating duty		O-0.3s-CO-15s-CO													
apacitance current switching		C2													
Rated closing control voltage	(V)	DC 24~30V, DC 48~60V, DC 110V, DC 125V, DC 220V, AC 48V, AC 100~130V, AC 220~250V													
Rated trip control voltage	(V)	DC 24~30V, DC 48~60V, DC 110V, DC 125V, DC 220V, AC 48V, AC 100~130V, AC 220~250V													
Mechanical endurance	(Operations)	M2 (10,000)													
Electrical endurance		Reference Standard (page 88)													
Standard aux. contacts	Type	4a4b, 10a10b													
	Rated Continuous current	DC 10A													
	Baeaking capacity	600W													
	Endurance (Mechanical, Interrupting)	(Operations)	10,000												
Operate temperature	Low	-40°C													
	High	-40°C													
Rated opening time	(sec)	≤ 0.04													
Rated closing time	(sec)	≤ 0.06												≤ 0.07	
Installation	Fixed	P type													
	Draw-out	H type													
Phase distance	(mm)	150	210	254	150	210	254	150	210	254	150	210	254	254	
Weight	Ha, Cradle ¹⁾	(kg)	90	-	-	-	100	-	90	-	-	-	100	-	-
	He, Cradle ²⁾	(kg)	375	405	-	-	425	-	375	405	-	-	425	-	-
	Hf, Cradle ³⁾	(kg)	310	340	-	-	360	-	310	340	-	-	360	-	-
	H, Circuit Breaker ⁴⁾	(kg)	130	140	-	-	160	-	130	140	-	-	160	-	-
	H, Circuit Breaker ⁵⁾	(kg)	115	120	-	-	145	-	115	120	-	-	145	-	-
	P, Circuit Breaker	(kg)	85	100	110	100	115	125	85	100	110	100	115	125	125
Applicable standard		IEEE Std C37.09, ANSI C37.54												IEEE Std C37.09	

1) MCSG Cradle type

2) Compact MCSG type(Arc)

3) Compact MCSG type(Non-Arc)

4) VCB for Compact MCSG type(Arc)

5) VCB for Compact MCSG type(Non-Arc)

* H type is a box type cradle with CB compartment style structure.

Ratings - 38kV 31.5/40kA 1200/2000A

Susol

UVH-38



Item		UVH-38 □ 32,40 □ 12,20		
Rated maximum voltage	(kV)		38	
Rated continuous current	(A)	1200		2000
Rated power frequency	(Hz)		60	
Power frequency withstand voltage	(kA)		80	
Full wave lightning impulse withstand voltage	(kA)		170	
Rated short-time current	r.m.s.		31.5/40	
	Peak		81.9/104	
Short-time current duration	(sec)		4	
Rated short-circuit current	Breaking		31.5/40	
	Making		81.9/104	
Rated interrupting capacity	(MVA)		2074/2633	
Rated Interrupting time	(cycle)		3	
Standard operating duty			O-0.3s-CO-15s-CO	
apacitance current switching			C2	
Rated closing control voltage	(V)	DC 48V, DC 110V, DC 125V, DC 220~250V, AC 48V, AC 110V, AC220V		
Rated trip control voltage	(V)	DC 48V, DC 110V, DC 125V, DC 220~250V, AC 48V, AC 110V, AC220V		
Mechanical endurance	(Operations)		M2 (10,000)	
Electrical endurance			Reference Standard (page 88)	
Standard aux. contacts	Type		4a4b, 10a10b	
	Rated Continuous current		DC 10A	
	Baeaking capacity		600W	
	Endurance (Mechanical, Interrupting)	(Operations)		10,000
Operate temperature	Low		-40°C	
	High		-40°C	
Rated opening time	(sec)		≤ 0.04	
Rated closing time	(sec)		≤ 0.06	
Installation	Fixed		P type	
	Draw-out		H type	
Phase distance	(mm)		300	
Weight	Ha, Cradle1	(kg)	350	
	He, Cradle2	(kg)	400	
	Hf, Cradle3	(kg)	360	
Applicable standard			IEEE Std C37.09	

Ratings - 4.76/15kV 40/50kA 1200/2000/3000A

Susol

VH-05/15



Item	VH-05 □ 40,50 □ 12,20,30			VH-15 □ 40,50 □ 12,20,30			
	Rated maximum voltage (kV)	4.76			15		
Rated continuous current (A)	1200	2000	3000	1200	2000	3000	
Rated power frequency (Hz)	60						
Power frequency withstand voltage (kA)	19			36			
Full wave lightning impulse withstand voltage (kA)	60			95			
Rated short-time current r.m.s. (kA)	40/50						
Rated short-time current Peak (kA)	104/130						
Short-time current duration (sec)	2						
Rated short-circuit current Breaking (kA)	40/50						
Rated short-circuit current Making (kA)	104/130						
Rated interrupting capacity (MVA)	330/412			1040/1300			
Rated Interrupting time (cycle)	3						
Standard operating duty	O-0.3s-CO-3min-CO						
apacitance current switching	C2						
Rated closing control voltage (V)	DC 48V, DC 110V, DC 125V, DC 220~250V, AC 48V, AC 110V, AC220V						
Rated trip control voltage (V)	DC 48V, DC 110V, DC 125V, DC 220~250V, AC 48V, AC 110V, AC220V						
Mechanical endurance (Operations)	M2 (10,000)						
Electrical endurance	Reference Standard (page 88)						
Standard aux. contacts	Type	4a4b, 10a10b					
	Rated Continuous current	DC 10A					
	Baeaking capacity	600W					
	Endurance (Mechanical, Interrupting) (Operations)	10,000					
Operate temperature	Low	-30°C					
	High	40°C					
Rated opening time (sec)	≤ 0.04						
Rated closing time (sec)	≤ 0.06						
Installation	Fixed	P type					
	Draw-out	H type					
Phase distance (mm)	254						
Weight (kg)	H, Cradle	248	248	286	248	248	286
	H, Circuit Breaker	230	230	265	230	230	265
Applicable standard	IEEE Std C37.09						

Accessory

Susol

Mounting Position	Type	Accessory	Supplied as			Remarks	page
			UVL-05/15/27	UVH-38	VH-05/15		
Breaker (Internal)	M	Motor	●	●	●	Attached at the factory	36
	CC	Closing Coil	●	●	●	Attached at the factory	37
	TC	Trip Coil	●	●	●	Attached at the factory	38
	A1	Secondary Trip Coil	Option	Option	Option	Attached at the factory	39
	SA (SB)	Auxiliary Contact 4a4b	●	●	-	Attached at the factory	41
		Auxiliary Contact 10a10b	Option	Option	-		
	SC1	Auxiliary Contact 3a3b	-	-	●	Attached at the factory	42
	SC2	Auxiliary Contact 4a4b	-	●	-	Attached at the factory	42
	SC4	Auxiliary Contact 10a10b	-	Option	-	Attached at the factory	42
	U	Under Voltage Trip Coil	Option	Option	-	Attached at the factory	43
	A3	Position S/W(Test: 1a1b, Connect: 2b)	Option	-	-	Attached at the factory	44
	A4	Position S/W(Test: 2a, Connect: 2a)	Option	-	-	Attached at the factory	44
	A5	Position S/W(Test: 1a1b, Connect: 1a1b)	Option	-	-	Attached at the factory	44
	A6	Latch Checking Switch	-	Option	Option	Attached at the factory	44
	-	Counter	●	●	●	Attached at the factory	42
	A7	Keylock	Option	Option	Option	Attached at the factory	45
	A8	Button Padlock	Option	Option	Option	Attached at the factory	46
	A9	Button cover	Option	Option	Option	Attached at the factory	47
	AA	Lead Wire: A/B type connector	Option	Option	Option	Attached at the factory	48
	AB	Plug/Terminal for Lead Wire	Option	Option	Option	Attached at the factory	48
	AC	Plug Interlock	●	-	-	Attached at the factory	49
	AD	Padlock (H type)	●	-	-	Attached at the factory	49
	AE	MOC(Mechanical Operated Cell Switch)	●	●	●	Attached at the factory	50
	AI	Mecha Shaft Interlock Lever	Option	-	-	-	-
	AM	Keylock(KirkKey, CAMLOCK Type)	Option	-	-	Attached at the factory	45
	AN	Keylock(KirkKey, CN22 Type)	Option	-	-	Attached at the factory	45
	AP	Keylock(KirkKey, Double CAMLOCK Type)	Option	-	-	Attached at the factory	45
	AV	CT operated coil 1A	Option	-	-	Attached at the factory	40
	AW	CT operated coil 5A	Option	-	-	Attached at the factory	40
	AX	Button Padlock In Open	Option	-	-	Attached at the factory	46
		Position padlock	-	●	●	Attached at the factory	51
		Mechanical position indicator	●	●	●	Attached at the factory	51
		Auto connection	-	●	●	Attached at the factory	52
	Code plate	-	-	●	Attached at the factory	52	
	Charge interlock	●	-	●	Attached at the factory	-	
	Auto discharge	-	●	-	Attached at the factory	-	
	Trip coil monitoring contact	●	●	●	Attached at the factory	53	
Breaker (External)	CTD1	Condenser Trip Device(AC110V)	Option	Option	Option	-	55
	CTD2	Condenser Trip Device(AC220V)	Option	Option	Option	-	55
	UDC1	UVT Time Delay Controller(AD110V)	Option	Option	Option	-	56
	UDC2	UVT Time Delay Controller(AD220V)	Option	Option	Option	-	56
	UDC3	UVT Time Delay Controller(AD48V)	Option	Option	Option	-	56
	CTU	Coil Test Unit	Option	Option	Option	-	54
	TM	Temperature Monitoring	Option	Option	Option	-	57



* ●: Basic Installation

Mounting Position	Type	Accessory	Supplied as			Remarks	page
			UVL-05/15/27	UVH-38	VH-05/15		
Cradle	AE	Shutter padlock	●	●	-	Attached at the factory	58
	AF	TOC(Truck Operated Cell Switch)	●	●	●	Attached at the factory	58, 64
	AG	MOC(Mechanical Operated Cell Switch)	●	●	●	Attached at the factory	59, 63
	AH	Door	Option	Option	-	Attached at the factory	59
	AJ	Door Interlock	Option	Option	-	Attached at the factory	60
	AK	Door Emergency Push Button	Option	Option	-	Attached at the factory	60
	AL	Temperature Sensor	Option	Option	Option	Attached at the factory	61
	AM	Type H Lead Wire 3a3b	-	-	●	Attached at the factory	62
	AM	Type H Lead Wire 4a4b	Option	●	-	Attached at the factory	62
	AN	Type H Lead Wire 10a10b	Option	Option	-	Attached at the factory	62
	AS	Bushing Barrier(170kV for 38kV)	-	Option	-	Attached at the factory	-
		Door padlock	●	-	-	Attached at the factory	62
		Auto connection	-	●	●	Attached at the factory	52
		Charge interlock	●	-	●	Attached at the factory	63
		Auto discharge	-	●	-	Attached at the factory	-

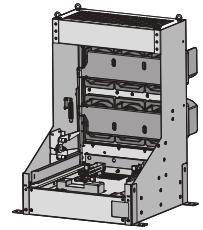

Accessory

Susol

Motor: M

Installed inside of a breaker as standard

UVL type

- Charge the closing spring of a circuit breaker by the external power source. When the charging is complete, control power of the motor will be "OFF" by the built-in Limit S/W. Without the external power source, charge manually.

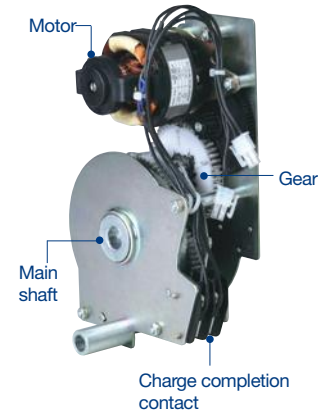
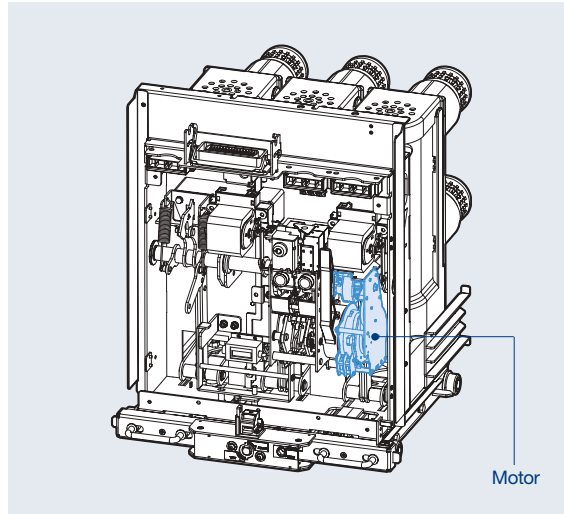

	UVL type							
Input voltage (Vn)	DC 24~30V	DC 48~60V	DC 110V	DC 125V	DC 220~250V	AC 48V	AC 100~130A	AC 200~250V
Load current (A)	≤ 5	≤ 3	≤ 1	≤ 1	≤ 0.5	≤ 3	≤ 1	≤ 0.5
Starting current (A)	5 times of load current							
Charge time	Within 5 sec.							

Note) Rated operation and control voltage range, see page 40.

VH/UVH type

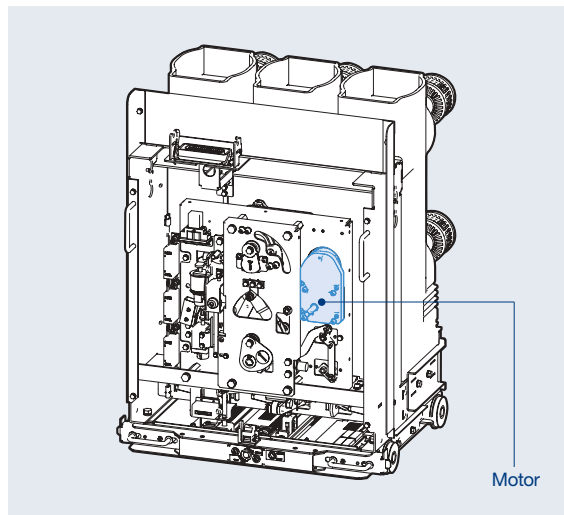

	VH/UVH type						
Input voltage (Vn)	DC 48V	DC 110V	DC 125V	DC 220~250V	AC 48V	AC 110V	AC 220V
Load current (A)	≤ 6	≤ 3	≤ 3	≤ 2.6	≤ 6	≤ 3	≤ 2.6
Starting current (A)	≤ 30	≤ 20	≤ 20	≤ 17	≤ 30	≤ 20	≤ 17
Charge time	Within 12 sec.						

Note) Rated operation and control voltage range, see page 40.

Closing Coil: CC

Installed inside of a breaker as standard

UVL type

- It is a control device which closes a circuit breaker, when applying voltage continuously or instantaneously over 200ms to the coil control terminals.

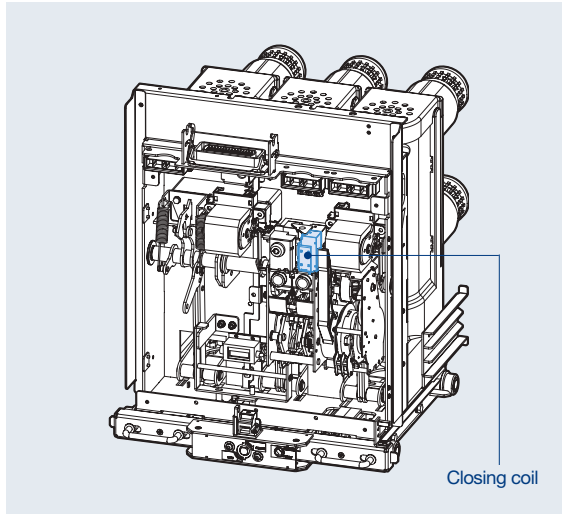

Input voltage (Vn)	UVL type							
	DC 24~30V	DC 48~60V	DC 110V	DC 125V	DC 220~250V	AC 48V	AC 100~130V	AC 200~250V
Power consumption (inrush, VA)	200							
Power consumption (steady, VA)	≤ 5							

Note) Rated operation and control voltage range, see page 40.

VH/UVH type

- It is a control device which closes a circuit breaker, when applying voltage continuously about 45ms to the coil control terminals. Electrical pumping preventing circuit is built in.

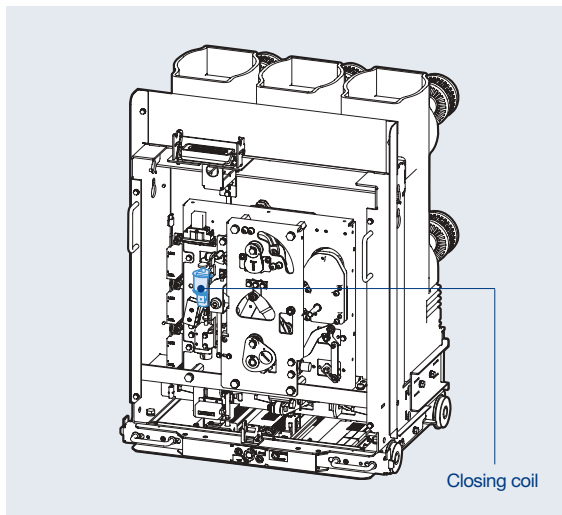

Input voltage (Vn)	VH/UVH type						
	DC 48V	DC 110V	DC 125V	DC 220~250V	AC 48V	AC 110V	AC 220V
Rated current (A)	≤ 8	≤ 3	≤ 3	≤ 2.5	≤ 8	≤ 3	≤ 2.5

Note) Rated operation and control voltage range, see page 40.

Accessory

Susol

Trip Coil: TC

Installed inside of a breaker as standard

UVL type

- It is a control device which trips a circuit breaker from remote place, when applying voltage continuously or instantaneously over 35ms to coil control terminals.
- When UVT coil is installed, its location is changed.

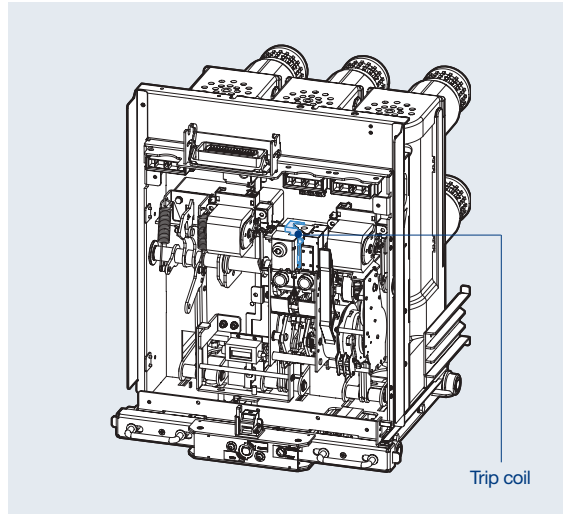

Input voltage (Vn)	UVL type							
	DC 24~30V	DC 48~60V	DC 110V	DC 125V	DC 220~250V	AC 48V	AC 100~130V	AC 200~250V
Power consumption (inrush, VA)	200		400			200		
Power consumption (steady, VA)	≤ 5		-			≤ 5		

Note) Rated operation and control voltage range, see page 40.

VH/UVH type

- It is a control device which trips a circuit breaker, when applying voltage continuously or instantaneously over 35ms to the coil control terminals.

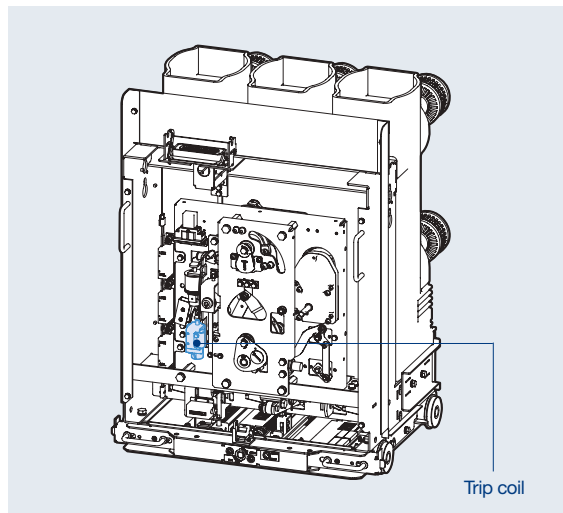

Input voltage (Vn)	VH/UVH type						
	DC 48V	DC 110V	DC 125V	DC 220~250V	AC 48V	AC 110V	AC 220V
Rated current (A)	≤ 8	≤ 3	≤ 3	≤ 2.5	≤ 8	≤ 3	≤ 2.5

Note) Rated operation and control voltage range, see page 40.

Secondary Trip Coil: A1

Installed inside of a breaker as an option

UVL type

- It is a control device which trips a circuit breaker doubly from the outside. If the trip coil (T) fails, it can trip a circuit breaker safely.
- Trip coil: Install it at existing location.
- Secondary trip coil: Install it on the right side of the trip coil.
- It is not available with UVT coil when installing secondary trip coil.

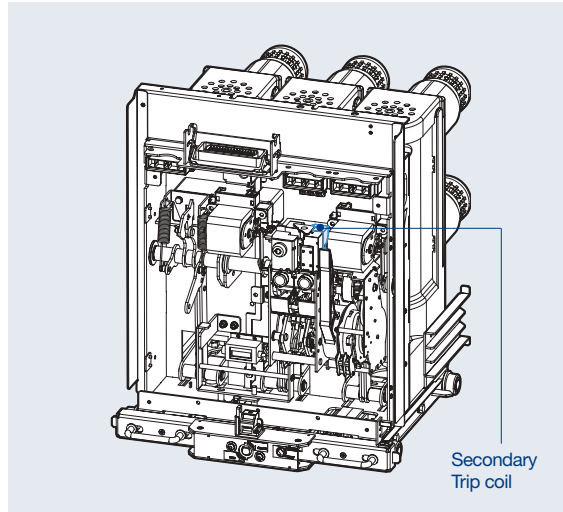

Input voltage (Vn)	UVL type							
	DC 24~30V	DC 48~60V	DC 110V	DC 125V	DC 220~250V	AC 48V	AC 100~130V	AC 200~250V
Power consumption (inrush, VA)	200		400			200		
Power consumption (steady, VA)	≤ 5		-			≤ 5		

VH/UVH type

- It is a control device which trips a circuit breaker doubly from the outside. If the trip coil (T) fails, it can trip a circuit breaker safely.
- It is not available with UVT coil when installing secondary trip coil.

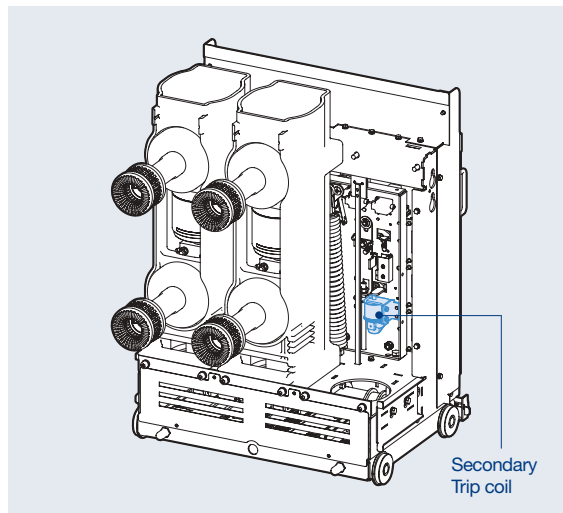

Input voltage (Vn)	VH/UVH type						
	DC 48V	DC 110V	DC 125V	DC 220~250V	AC 48V	AC 110V	AC 220V
Rated current (A)	≤ 8	≤ 3	≤ 3	≤ 2.5	≤ 8	≤ 3	≤ 2.5

Accessory

Susol

Rated operation and control voltage range

Rated control voltage range	DC Voltage range		Remarks	Rated control voltage range	AC Voltage range		Remarks
	Motor, Closing	Trip			Motor, Closing, Trip		
24	-	14~28		24	-		
48	38~56	28~56		48	-		
125	100~140	70~140		120	104~127		
250	200~280	140~280		240	208~254		
Applied standard	IEEE C37.09			Applied standard	IEEE C37.09		

CT operated coil

Installed inside of a breaker as an option

UVL type : AV, AW

- This trip coil uses the output of the CT as its control power source and is used with over current relay in combination. Two current trip coils are supplied.
- Coil impedance(Z) is like below
 - 1A: 160Ω or less, Operating current AC 1A (AV)
 - 5A: 6Ω or less, Operating current is AC 5A (AW)
- CT must be installed at load side.
If it is installed at bus side there is the danger of malfunction or damage to CT.
- Don't disconnect the control power connector on main power is live condition at connect position.
Otherwise there is the danger of malfunction or damage to CT.

* CT is recommended to use 15VA 5P10 and more.

* This coil is applicable to non-effectively grounded neutral systems.

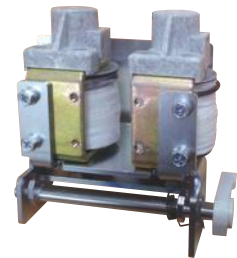
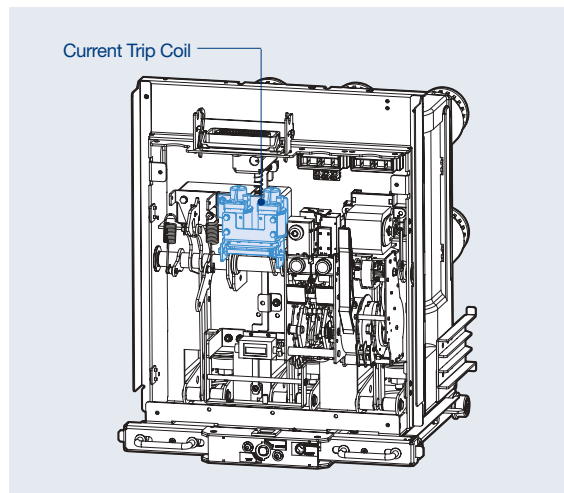

Auxiliary Contact: SA

Installed inside of a breaker as an option

UVL type

- It is a contact used to monitor ON/OFF status of a breaker from remote place.
- The auxiliary contacts supplied as standard configuration is 4a4b. 10a10b is also available on request.

Item	UVL/VH/UVH-27 type
Standard	4a4b
Optional	10a10b

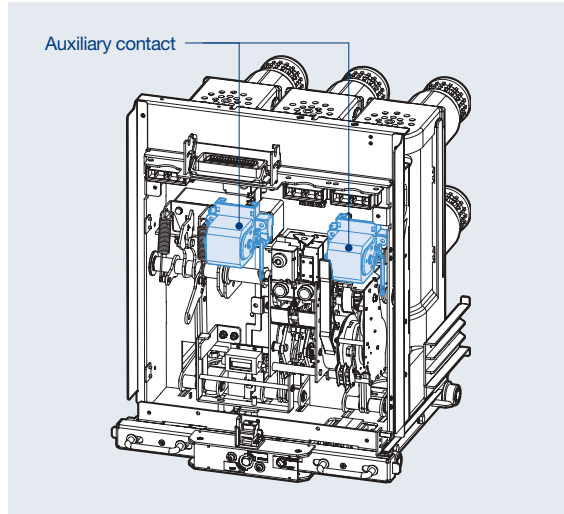

VH/UVH type

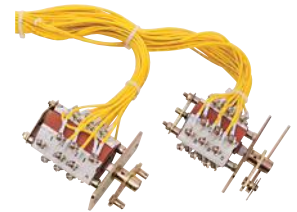
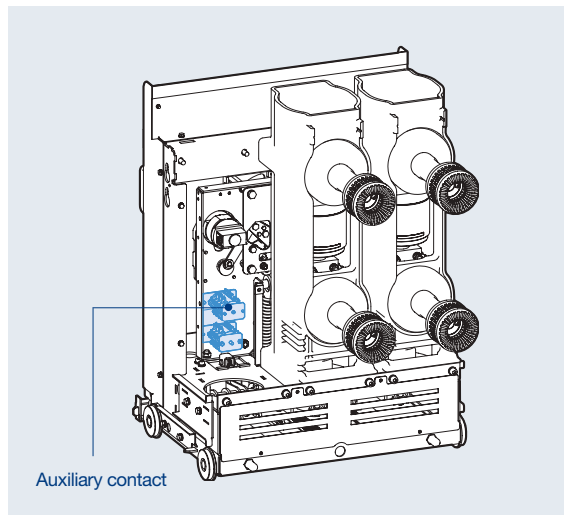

UVL/VH/UVH type					
	Item		Resistive load (A)	Inductive load (A)	Remarks
Contact configuration	AC	250V	10	5	For all models
		125V	10	5	
	DC	250V	10	5	
		125V	10	5	
		30V	10	5	

Accessory

Susol

Auxiliary Contact: SC1

Installed inside of a breaker as an option

VH-05/15 type

- It is a contact used to monitor ON/OFF status of a breaker from remote place.
- The auxiliary contacts supplied as standard configuration is 3a3b.
- Two(2) "Early b" auxiliary contact is provided. (Terminal No. 56-57, 58-59)

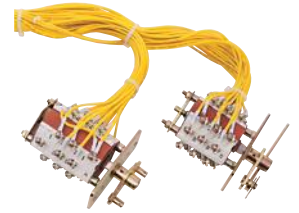
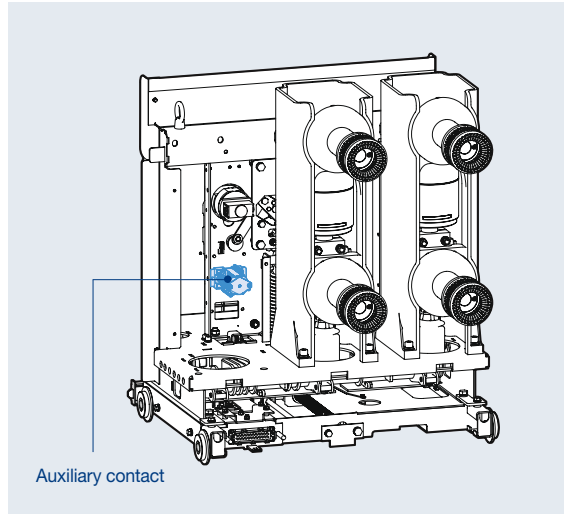

Item	Resistive load(A)	Inductive load(A)	
Contact configuration	DC 125V	10	5

Counter: C

Installed inside of a breaker as standard

UVL/VH/UVH type

- It displays the total number of ON/OFF operations of a breaker.



Under Voltage Trip Coil: U

Installed inside of a breaker as an option

UVL type

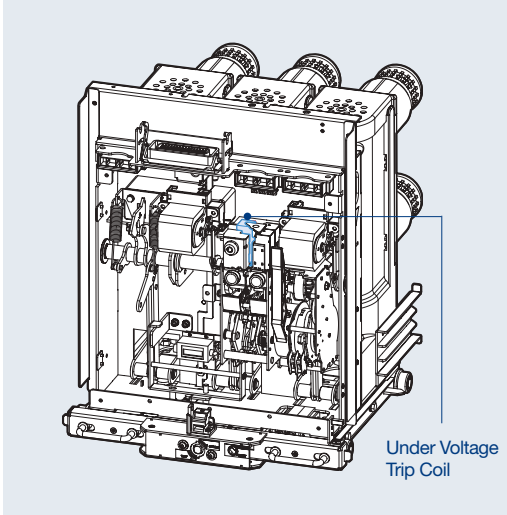

UVH type

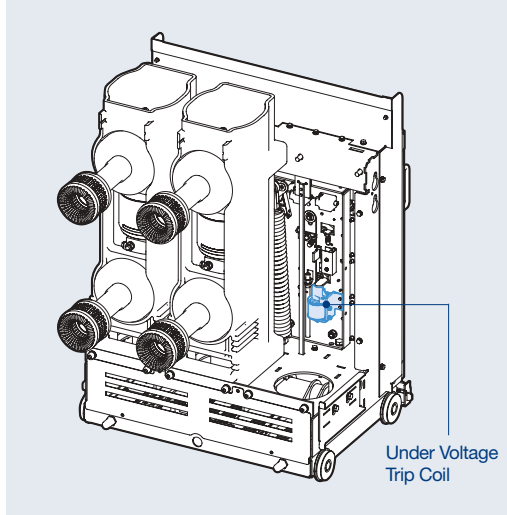

UVL type



VH/UVH type

- It is installed inside of a breaker to trip when the main power or control power voltage drops below certain value. Instantaneous type is only available with UVT coil and Time delay type is available by connecting UVT coil and UVT time delay controller.
- The closing of a circuit breaker is impossible mechanically or electrically if control power is not supplied to UVT. To close the circuit breaker, 65~85% of rated voltage should be applied.
- UVT and secondary trip coil will not be selected together.
* UVT is only applicable for Fixed type (P type)

1. UVT rated voltage and characteristic

- Operating voltage range: Pick up 0.65~0.85Vn, Drop out 0.4~0.6Vn
- Operating voltage ranges based on the minimum value of each rated voltage (Vn)

	UVL type							
Input voltage (Vn)	DC 24~30V	DC 48~60V	DC 110V	DC 125V	DC 220V	AC 48V	AC 100~130V	AC 200~250V
Power consumption (inrush, VA)	200							
Power consumption (steady, VA)	≤ 5							

	UVH type						
Input voltage (Vn)	DC 48V	DC 110V	DC 125V	DC 220V	AC 48V	AC 110V	AC 220V
Power consumption (inrush, VA)	350						
Power consumption (steady, VA)	≤ 10						

Accessory

Susol

Position Switch: A3, A4, A5

Installed inside of a breaker as an option

UVL type - H Cradle

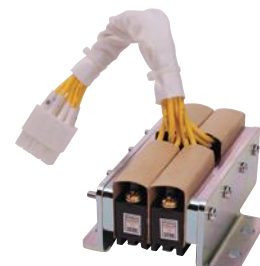
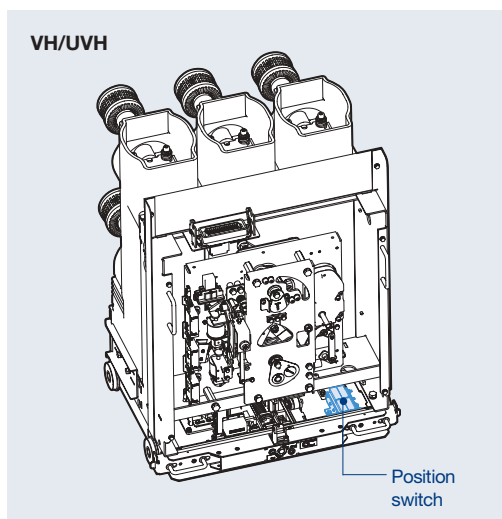
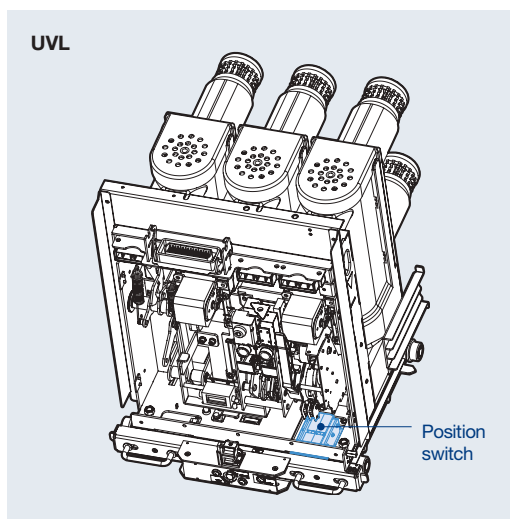

Large model (VH/UVH)

- This switch is used to indicate the breaker position (CONNECT, TEST), and contact configuration is 2a2a or 2a2b, 1a3b.

Contact configuration

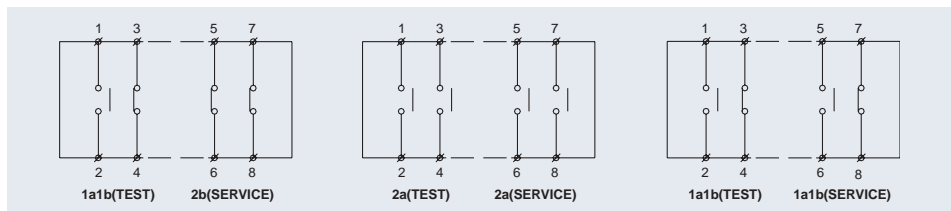

Latch checking switch: A6

Installed inside of a breaker as an option

VH/UVH type

- This switch works in conjunction with the mechanism of the breaker. It checks if the breaker is ready to be closed.
- When the mechanism is OFF and the closing spring is at charged status the switch becomes "ON", which means the mechanism is ready to be closed.
- If the latch is not in a proper position the switch prevents the breaker from closing. In case of VH type it is connected internally in series with the closing coil.

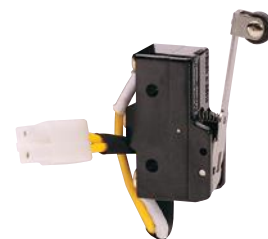
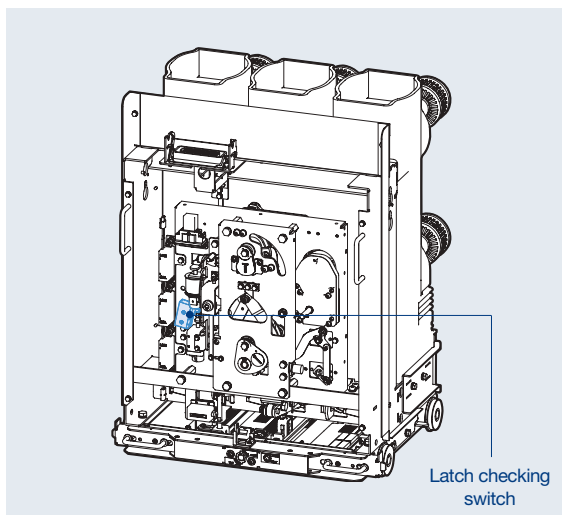

Keylock: A7, AM, AN, AP

Installed inside of a breaker as an option

UVL type

- The key is to unlock the locking device first to close the breaker electrically and mechanically.

*How to operate

- It is not possible to pull out the key in the unlocked position, possible only in locked status.
- Pushing "OFF" switch of a breaker turn the key counter-clockwise to the locked position and pull it out.
- It is not possible to close the breaker electrically and mechanically in the locked position.
- Insert the key and turn clockwise and then the breaker can be closed electrically and mechanically.

1. A7: KEYLOCK(NORMAL Type)
2. AM: KIRKKEY LOCK(CAMLOCK Type)
3. AN: KIRKKEY LOCK(CN22 Type)
4. AP: KIRKKEY LOCK(DOUBLE CAMLOCK Type)

* The KIRKKEY is not provided separately when ordering AM, AN or AP option. The assembling bracket and instruction manual are provided.

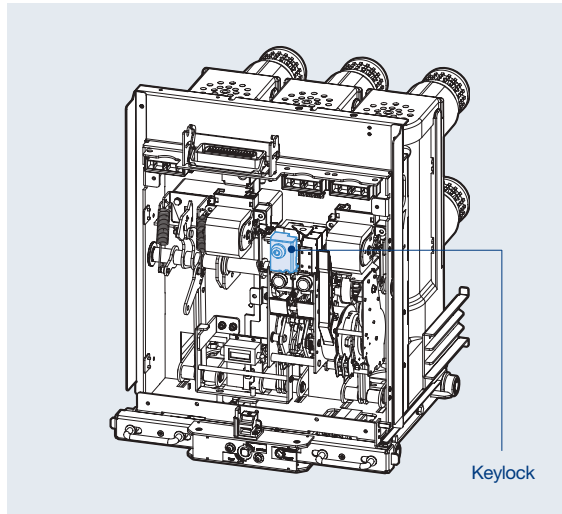

A7



AM



AN

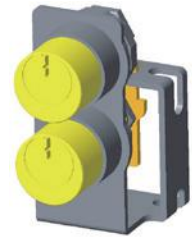

AP

VH/UVH type

*How to operate

- It is not possible to pull out the key in the unlocked position, possible only in locked status.
- Trip the breaker first and then turn the key counter-clockwise to the locked position and pull it out.
- It is not possible to close the breaker electrically and mechanically in the locked position.

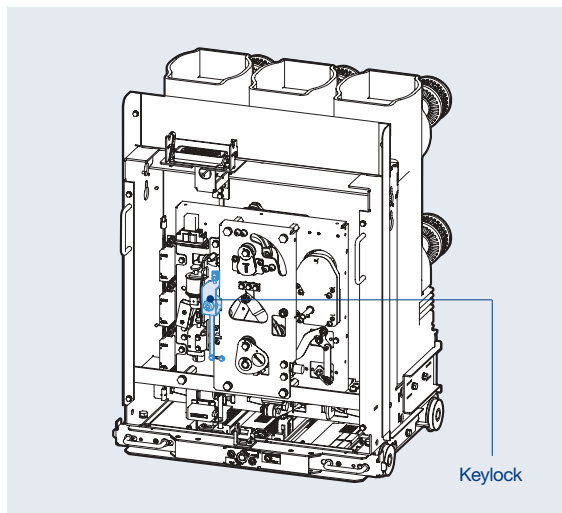

Accessory

Susol

Button Padlock: A8, AX

Installed outside of a breaker as an option

UVL type

- It is to prevent manual operation of ON/OFF button due to user's wrong handling.
- A8 option: It is not possible to handle ON/OFF manual operation under the "Button lock" status.
- AX option :It is not possible to handle ON/OFF manual/electrical operation under the "Button lock" status.

* Key lock is not supplied.

1. A8: KEYLOCK(NORMAL Type)
2. AX: Button Padlock In Open

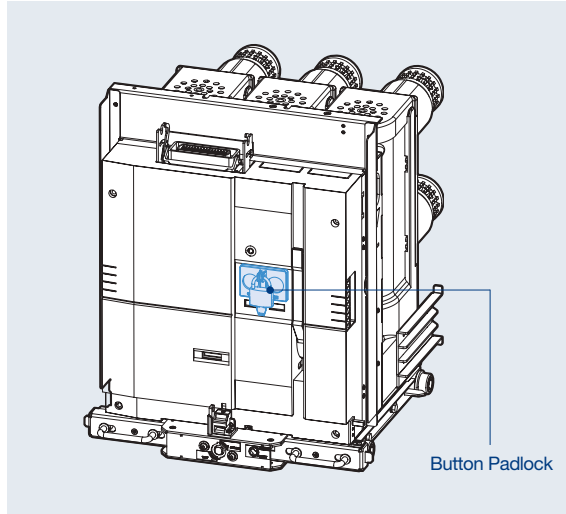

VH/UVH type

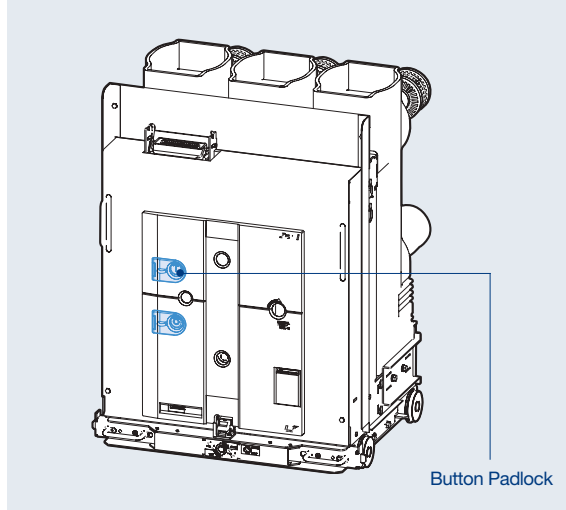

Button Cover: A9

Installed outside of a breaker as an option

UVL type

- It is a protection cover to prevent an accident due to unintended operation of ON/OFF button.
- Use the push-bar to operate the ON/OFF button.

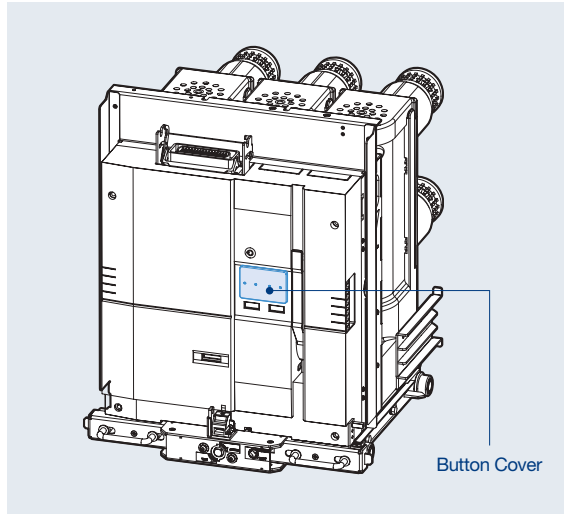

Push Bar

VH/UVH type

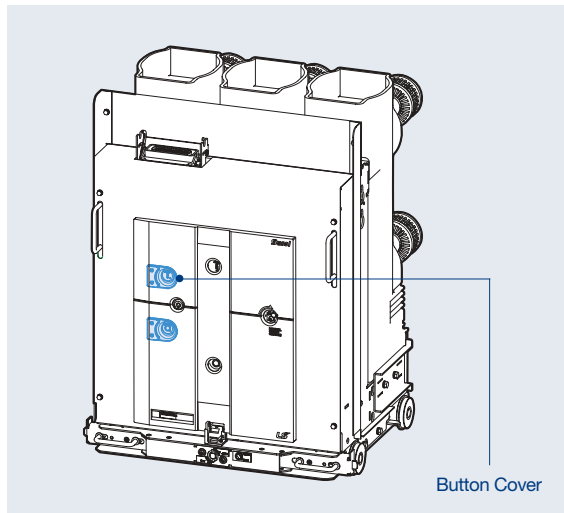

Push Bar

Accessory

Susol

Lead wire: AA

Supplied separately from a breaker as an option

UVL/UVH type

- It is to connect with the control circuit of a breaker from outside. (supply wire length: 2m)
- A type connector is supplied for P/E/F/G type of UVL VCB.
- B type connector is supplied for P type of VH/UVH VCB.
- In case of H type breaker of VL and VH models the Lead wire is installed in the cradle when supplied.

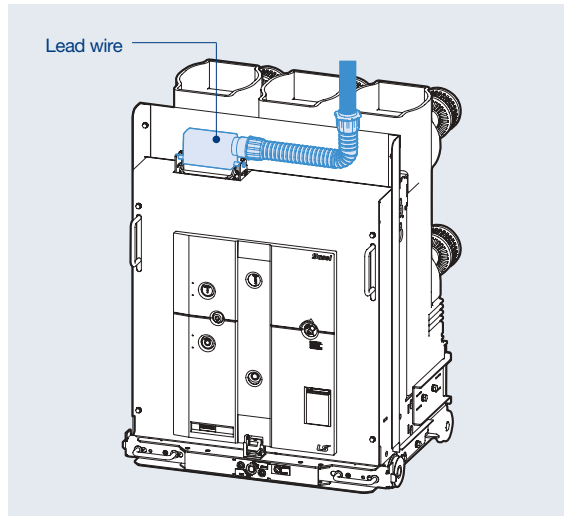

A type connector

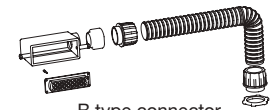

B type connector

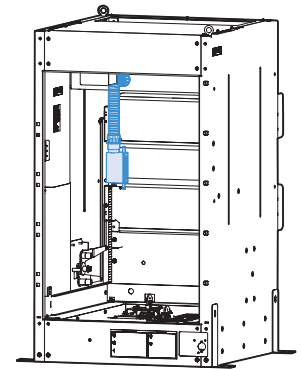

Supply ways of Lead wires by VCB model

VCB model	Cradle type	P	E	F	G	H
UVL		Enclosed in the breaker				Enclosed in the breaker Installed in the cradle (option)
VH/UVH		Enclosed in the breaker				Enclosed in the breaker Installed in the cradle (option)

Plug/Terminal for lead wire

Supplied separately from a breaker as an option

UVL/UVH type

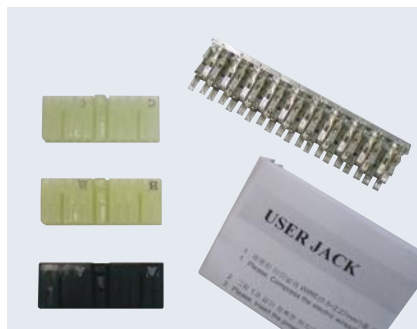

A type connector



B type connector

- It is connector to connect with the connector installed in the breaker. (supply connectors and terminal only for lead wire)
- Type of connector is depends on the type of connector installed in the breaker- A or B.

Plug interlock: AC

Installed inside of a breaker as an option

UVL type

- It checks if the control power connector on the cradle (H type) is connected with the connecting terminal of the breaker before the proceeding of draw-in or out.
- It is not allowed to separate the control power connector from the breaker in the position of draw-in /out or CONNECT, but TEST position.

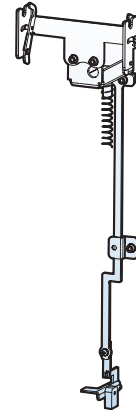
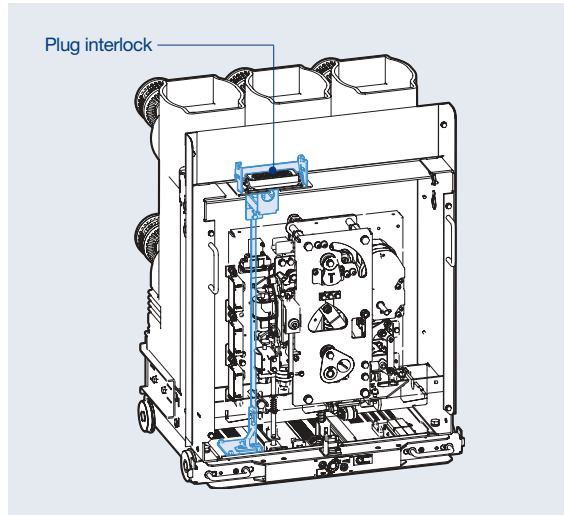

Padlock/Door racking interlock: AD

Installed outside of a breaker as an option

UVL type

- With this door options for H type cradle draw-in/out is allowed only when the door is closed.
- If draw-in /out is necessary when the door is open, use the operation lever put in the slot of the breaker handle. Insert it into the hole in the bottom of door interlock.
- Padlock is also optional, which can lock to prevent the draw-in/out of the breaker in the position of TEST and CONNECT.

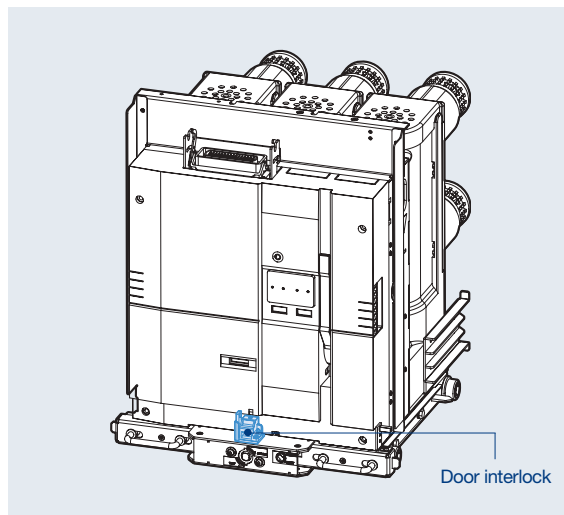

Accessory

Susol

MOC drive device: AE

Installed inside of a breaker as an option

UVL type

- It must be installed in the breaker to drive the MOC installed in H type cradle.
- MOC, Mechanically operated cell switch is the device to indicates the Closed/Trip status of VCB in 'CONNECT' position only.
- This MOC drive device in the breaker should be installed when MOC in the cradle is used.

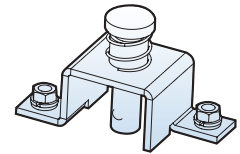
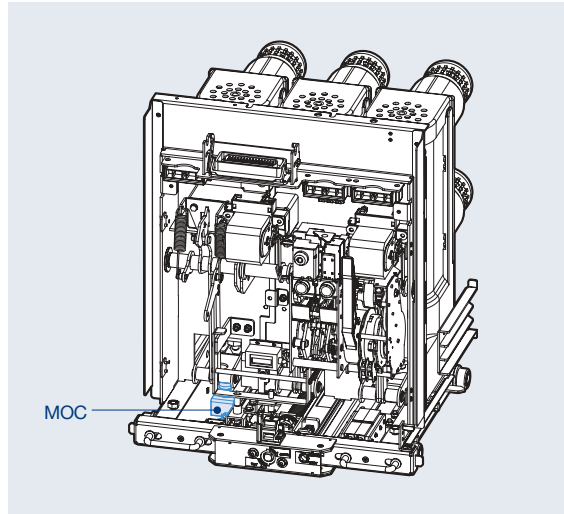

VH/UVH type

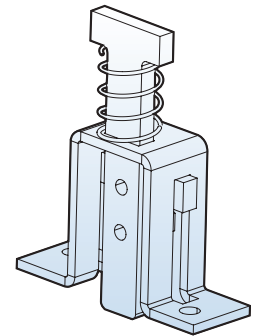
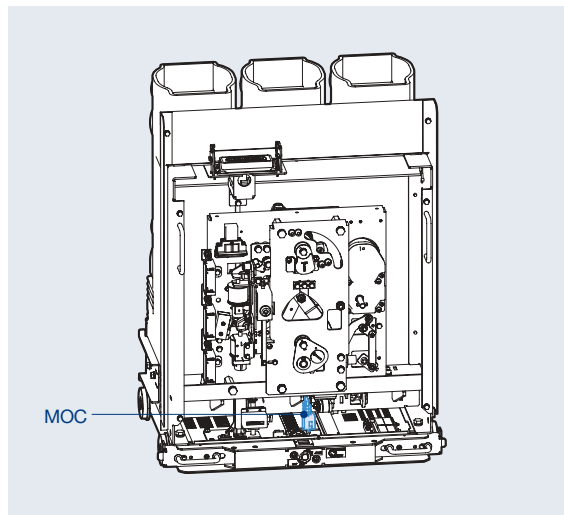

Position padlock

Installed inside of a breaker as an option

VH/UVH type

- It is located at the screw hole to prevent the draw-in and out of a breaker from the present position(Disconnected, Test or Connected)

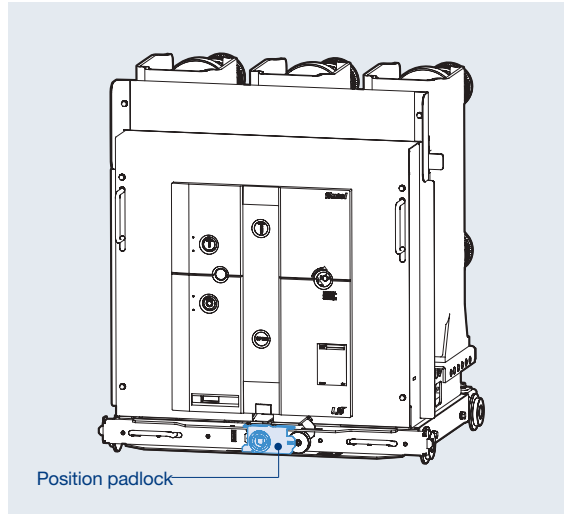

Mechanical position indicator

Installed inside of a breaker as an option

VH/UVH type

- It is located in the lower part of a breaker to check the present position - Disconnected, Test or Connected- easily.

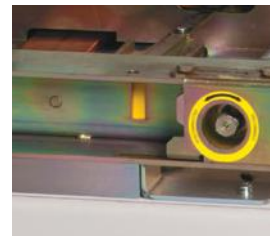
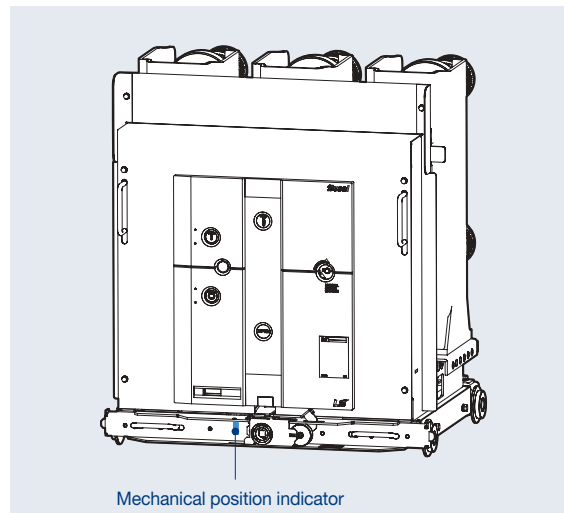

Accessory

Susol

Auto connection

Installed inside of a breaker as an option

VH/UVH type

- When the breaker is moved to 'Test' position from 'Disconnected' position the connector for control powers is automatically connected. In case of reverse moving of the breaker the connector is automatically disconnected.

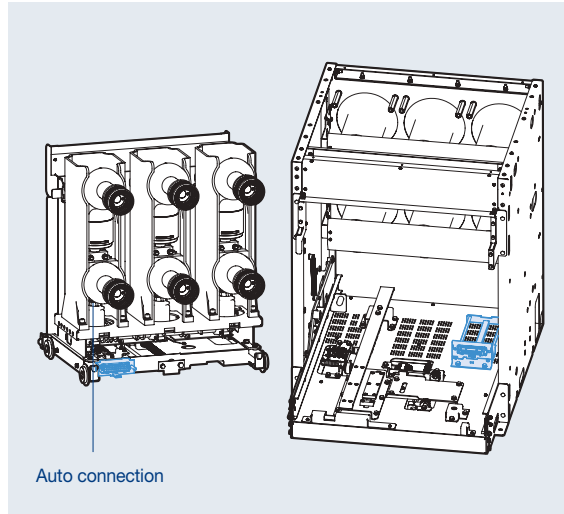

Code plate

Installed inside of a breaker as an option

VH-05/15 type

- When the breaker is inserted to the cradle, if the ratings does not match with the cradle, it mechanically prevents the breaker from being inserted into the cradle.

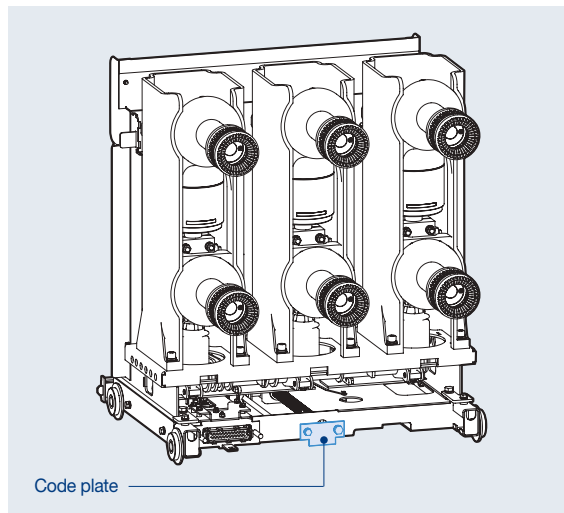

Trip coil monitoring contact

Installed inside of a breaker as an option

UVL type

- Device for monitoring the functions of the trip coils.
- Supplied as standard for VL model and optional for VH model.
- To monitor the trip coils connect its terminals with the trip coil monitoring relay as shown on the circuit diagram.
 - If the trip coil is normal: closed-circuit consisting
 - If the trip coil is damaged: open circuit
- 1) Terminals A5 and A6 monitor the trip coils in closed position of the breaker.
- 2) Terminal A6 and aux. contact terminal 34 monitor the trip coils in trip position of the breaker.
- Coil Test Unit is optional, which enable monitoring the coils by connecting in parallel with the trip coil operation switch.
- In case of UVL type this contact works with the trip coils such as T1, T2, T3, T4 and T5. For VH/UVH type it works with all trip coils.

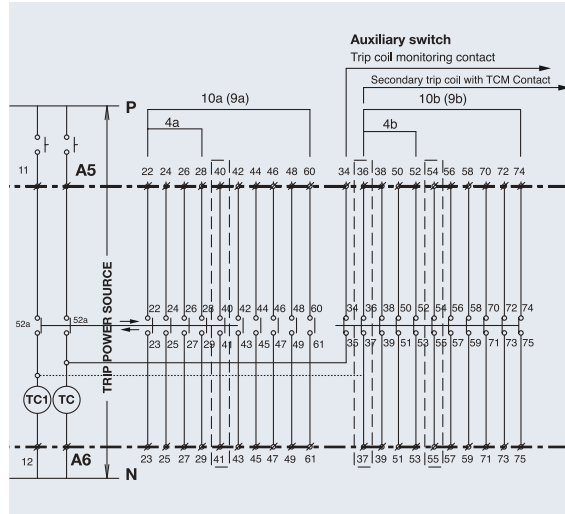

UVH type

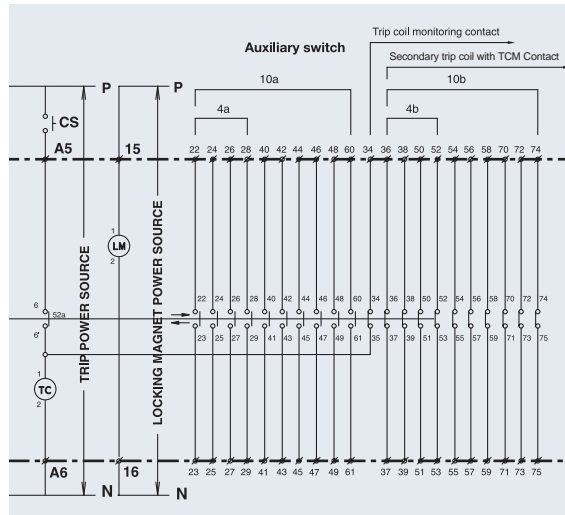

Accessory

Susol

Coil Test Unit: CTU

Installed outside of a breaker as an option

UVL/VH/UVH type

- When no current flows through the coil it gives the test current which does not cause the coil to operate to check whether the coil is disconnected or not.
 - If the test current flows normally: coil normal
 - If the test current does not flow through: coil disconnected

※ As it is connected in parallel with the control part of the coil the normal operation of the coil is not affected.

※ Monitoring of the running coils is not possible.

※ One test unit can monitor up to two coils.

1. Input voltage: AC/DC 75V~264V
2. Contact output
 - 1) 2×a contacts for Fail indication and 2×a contacts for Alarm
 - 2) 250Vac/10A Resistive, 30Vdc/10A Resistive
3. Disconnection test cycle is 12 seconds (Test LED blinks)
4. The default operation
 - If Fail happens (coil disconnected), Fail LED turns on and the Fail contacts become short state.
 - If Fail happens three times in series, Alarm LED turns on and the Alarm contacts become short state.
 - In order to clear the Alarm status push up DIP switch on the front and then push down it (Off → On → Off)

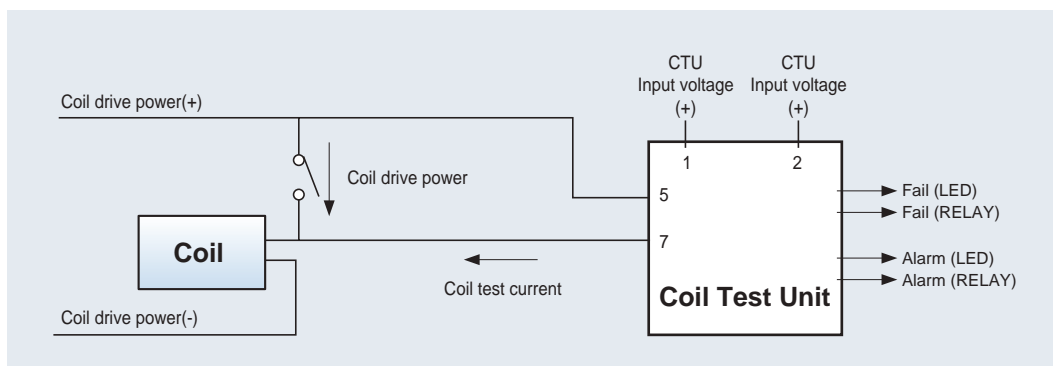
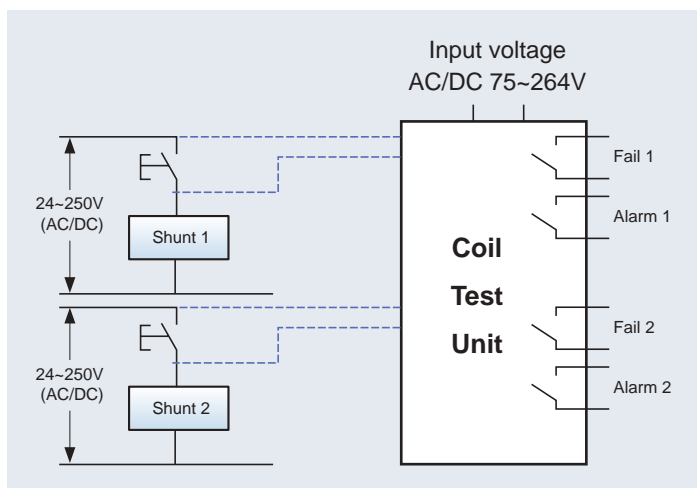
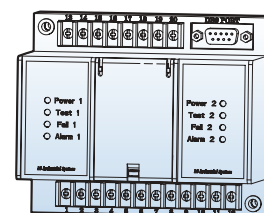

Condenser trip device: CTD

Installed outside of a breaker as an option

Ratings

Ratings	Specification	
	CB - T1	CB - T2
Model	CB - T1	CB - T2
Rated input voltage (V)	AC 100/110	AC 200/220
Frequency (Hz)	50/60	50/60
Rated charge voltage (V)	140/155	280/310
Charging time	Within 10sec.	Within 10sec.
Trip possible time	Within 30sec.	Within 30sec.
Range of Input voltage	85%~110%	85%~110%
Condenser capacity (μF)	1,000	560

UVL/VH/UVH type

- It gets a circuit breaker tripped electrically within regular time when control power supply is broken down and is used with Shunt coil, SHT. In case there is no DC power, It can be used as the rectifier which supplies DC power to a circuit breaker by rectifying AC power.
- Tripping within 30 seconds on the power failure is possible. However after that automatic trip circuit must be configured separately in the switchgear.



Terminal arrangement External dimension

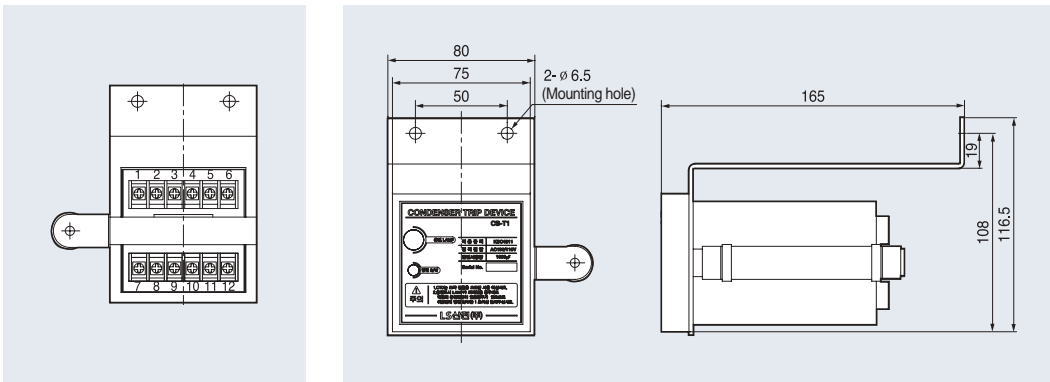

Circuit diagram

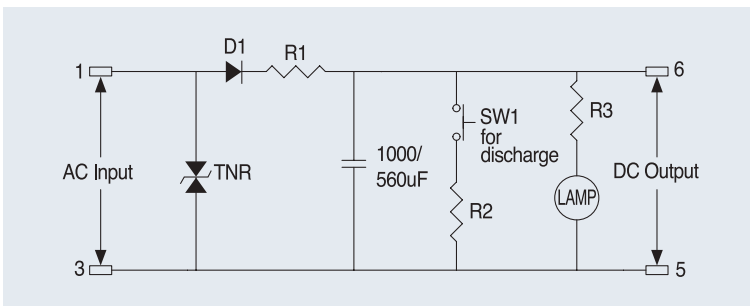

UVT Time delay: UDC

Installed outside of a breaker as an option

UVL/VH/UVH type

- UVT time delay, UDC is to delay the trip signal from UVT. Without UDC the breaker will be tripped instantaneously by the trip signal from UVT installed inside of the breaker even in the the momentary power failure.
- UDC can delay the trip time to avoid this unintended instantaneous trip in the event of such power failure.
- It can be installed on the cradle or inside of the switchgear.
- UDC provides output contacts for indication of trip status due to the UVT coil inside of the breaker. b contact is closed at normal state and a contact is closed at trip.



1. Characteristics

Rated voltage (Vn)		Operation voltage range (V)		Consumption (VA or W)		Time delay (ms)
DC (V)	AC (V)	Pick up	Drop out	Inrush	Steady - state	
48-60	48	0.65-0.85 Vn	0.4-0.65 Vn	200	≤ 5	0.5, 1, 1.5, 3
100-130	100-130					
200-250	200-250					

- Operating voltage ranges are based on the minimum value of each rated voltage (Vn)

2. Ratings of output contacts

Rated voltage (V)	Rated current (A), Resistive load	Max. switching voltage (A)	Max. switching current (A)
24V DC	≤ 12	110V DC 250V AC	15
120V AC	≤ 12		
250V AC	≤ 10		

3. Wiring diagram

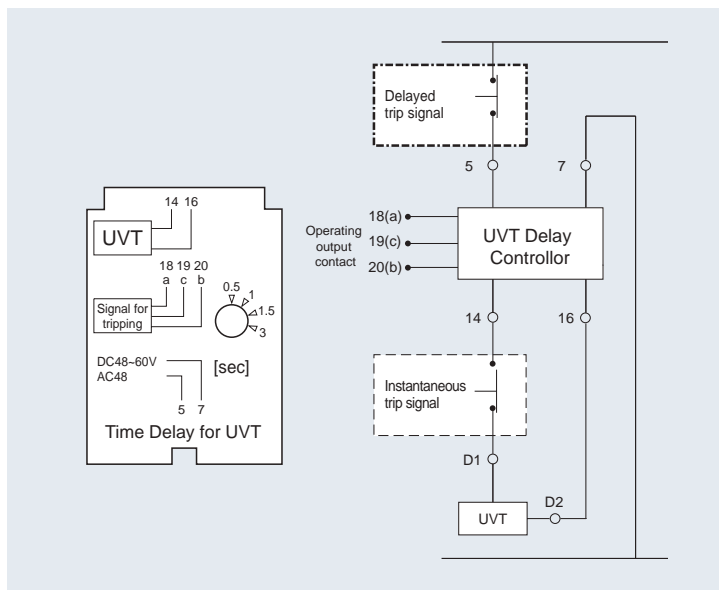

Temperature sensor and monitoring unit: TM

Installed outside of a breaker as an option

UVL/VH/UVH type

- Temperature Alarm Unit displays the input temperature detected through the temperature sensor installed in H-type cradle.
- Temperature sensor can be installed up to three (R, S, T phase).
- Temperature Alarm Unit converts the temperatures detected from the sensor in the cradle and displays the maximum value and can transmit it through communication.
- If the input temperature is above standard it may cause alarm.
Temperature Alarm Unit supports Modbus/RS-485 communication and contact us Profibus-DP communication.

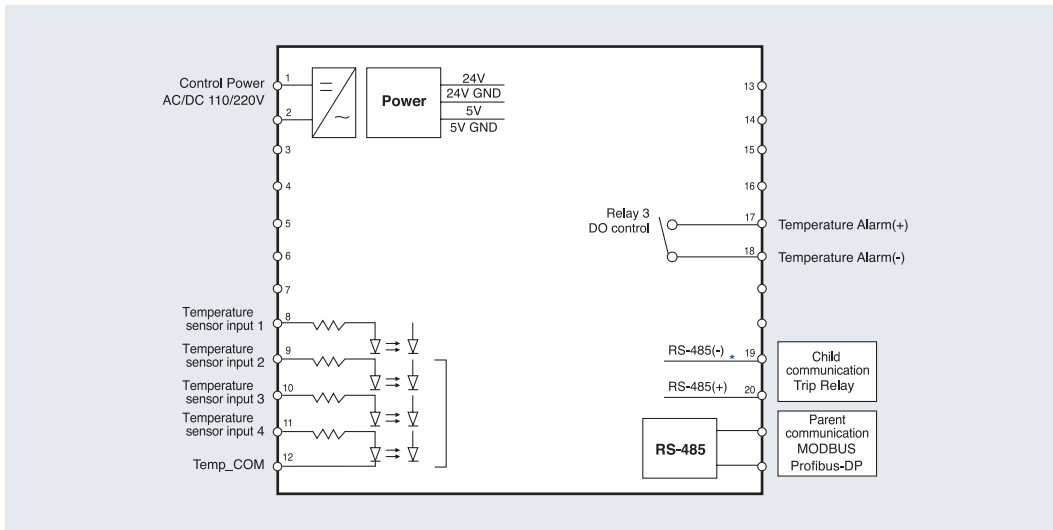
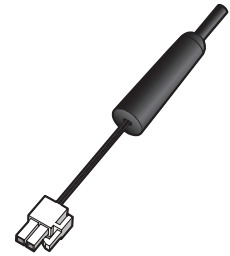
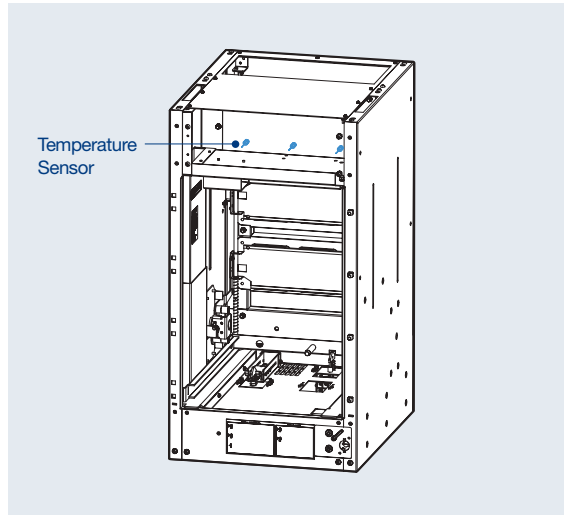

Temperature sensor and monitoring unit

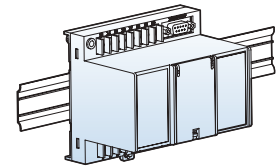

LED temperature display (°C): 10 ~ 150°C,
Warning
Display maximum value of temperatures

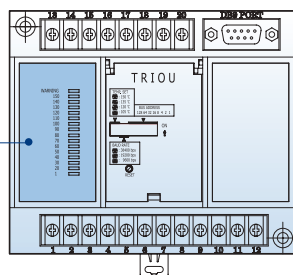

Accessory

Susol

Shutter padlock: AE

Built-in a cradle as an option

UVL/UVH type

It is the locking device to lock the primary and secondary shutter in closed state for safety while the breaker is drawn out for maintenance.

- When the breaker is drawn in, the shutter is automatically opened.
- There is a hole for padlock to lock the shutter.
- It can be applied only to H type cradle.

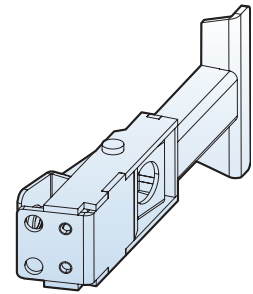
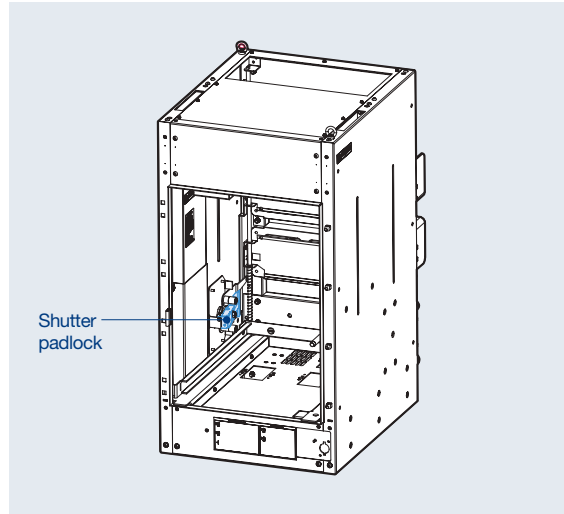

Truck operated cell switch (TOC: AF)

Built-in a cradle as an option

UVL/UVH type

- This auxiliary switch is used to indicate the 'CONNECT' position of VCB. It is installed in the bottom of a H type cradle and operated by the frame of a breaker.
- TOC is consisted of 4 cell switches with changeover contacts as below diagram.

Circuit diagram

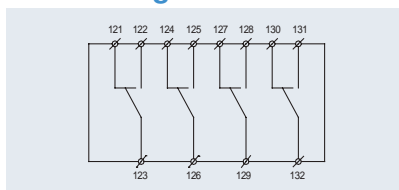

a Contact: 122-123, 125-126, 128-129, 131-132,
b Contact: 121-123, 124-126, 127-129, 130-132

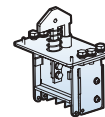
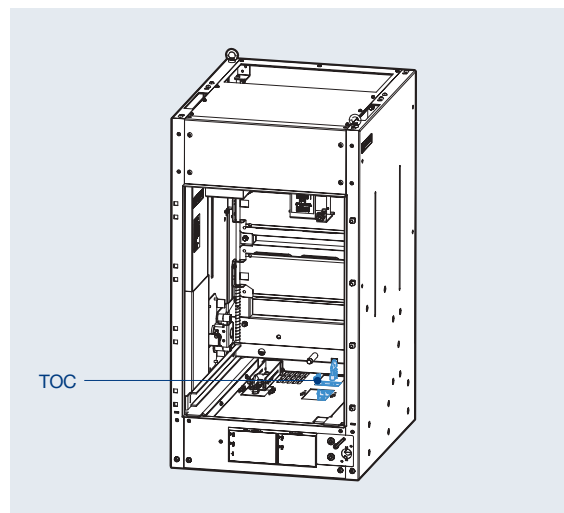

VL type

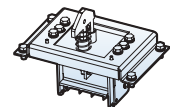

VH Type

Mechanical Operated Cell Switch (MOC)

Built-in a cradle as an option

UVL/UVH type

- This auxiliary switch is used to indicate the Close/Trip of VCB. It is operated mechanically at the CONNECT position and installed in the bottom of a H type cradle and operated by the frame of a breaker.
- MOC is consisted of 4 cell switches with changeover contacts as below diagram.

Circuit diagram

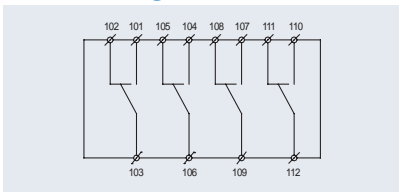

a Contact: 101-103, 104-106, 107-109, 110-112,
b Contact: 102-103, 105-106, 108-109, 111-112

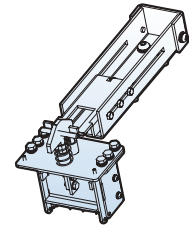
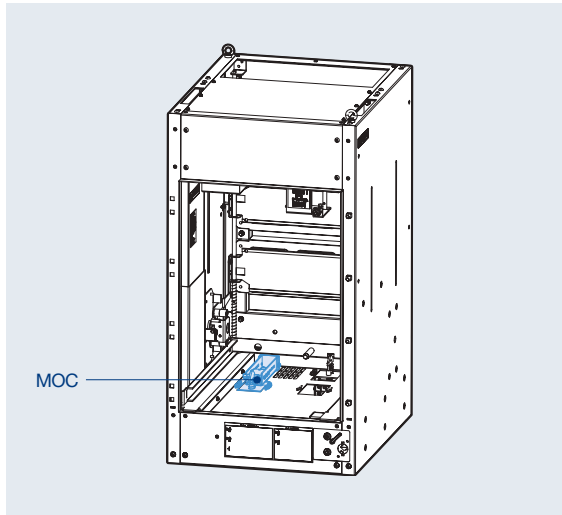

VL type

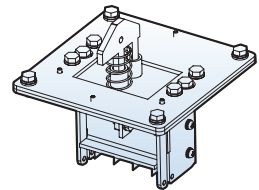

VH Type

Door: AH

Built-in a cradle as an option

UVL/UVH type

- It is outside door for H type cradle.
- Accessories are available for the door.

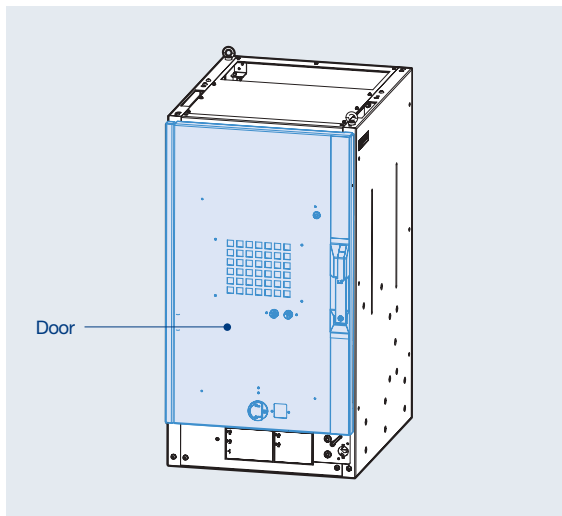

Accessory

Susol

Door Interlock: AJ

Built-in a cradle as an option

UVL/UVH type

- When the Door is installed to H type cradle, this door interlock prevents opening it at CONNECT position.

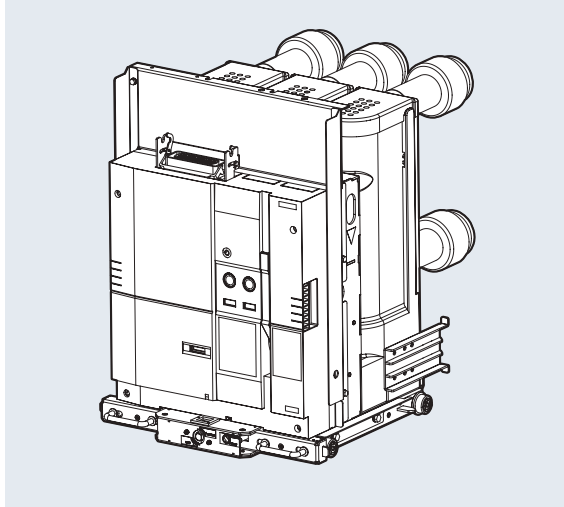

Door Emergency Push button: AK

Built-in a cradle as an option

UVL/UVH type

- It is used to enable the Close/Trip of the breaker manually from outside of the door installed to H type cradle during an emergency.
- Push the ON/OFF button by ON/OFF handle supplied separately.

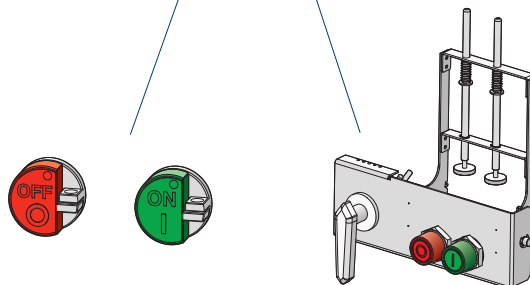
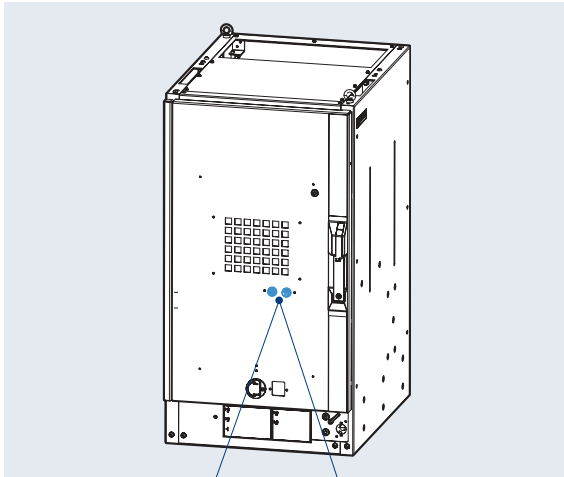

Door Emergency Push button

Temperature Sensor: AL

Built-in a cradle as an option

UVL/UVH type

- This sensor is used to detect the temperature in H-type cradle combined with Temperature monitoring unit.
- It can be installed up to three (R, S, T phase).

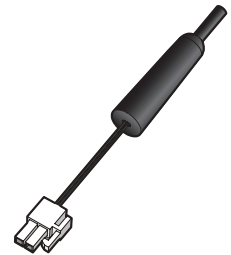
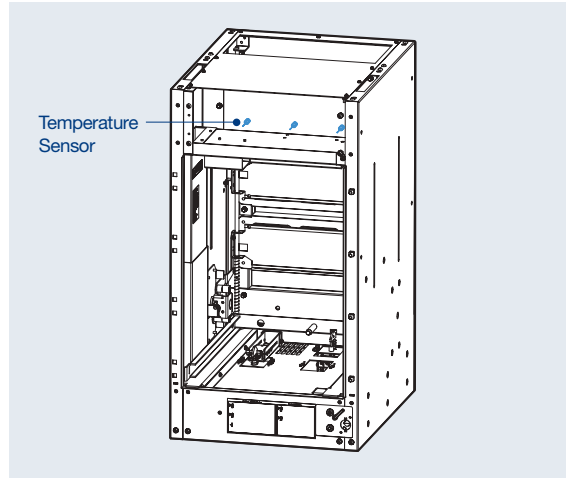

Racking In/Out handle

Susol VCB offers various kinds of handle suitable for each use of types and models. The order can be proceeded with the code below and ordering quantity is flexibly adjustable.

Type	Cradle		Racking in/out handle			Charging handle	
	Type	Code	Appearance	Description	Code	Appearance	
UVL	Ha, He, Hf	A	55223172407		Normal type	Not required	
		B	55223172403		Extention type (Normal)		
		C	55223172405		Universal type		
		D	55223172406		Extention type (Universal)		
VH/UVH	Ha, H	E	55213163003		Universal type	55213143006	

Racking in/out handle for cradle

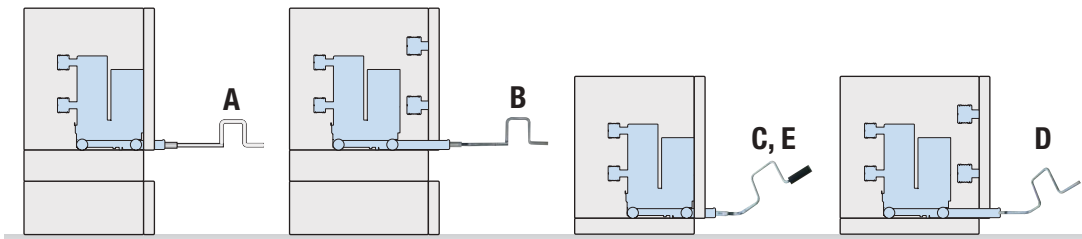

Accessory

Susol

Type H Cradle Lead Wire: AM, AN

Built-in a cradle as an option

UVL/UVH type

- In case of H type breaker of UVL and UVH models the Lead wire is installed in the cradle when supplied.
- 4a4b or 10a10b contacts are selectable according to the auxiliary contact of the breaker. Flame retardant cable is used for 4a4b.

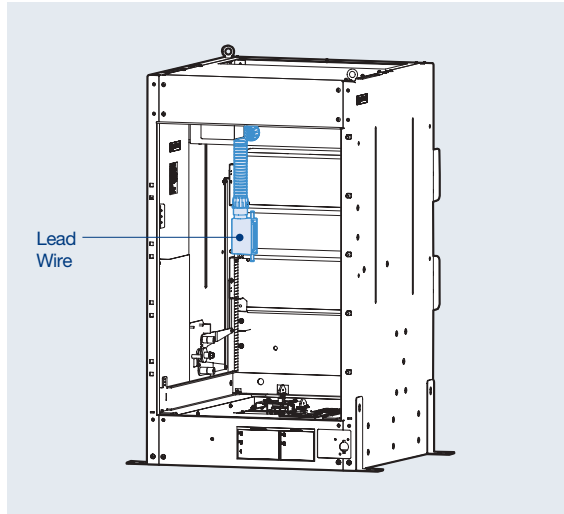

Door Padlock

Built-in a cradle as an option

UVL/UVH type

- It is supplied with a door for H type cradle as standard.
- It can be locked by separate padlock to prevent entering the manual handle.

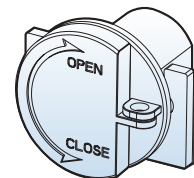
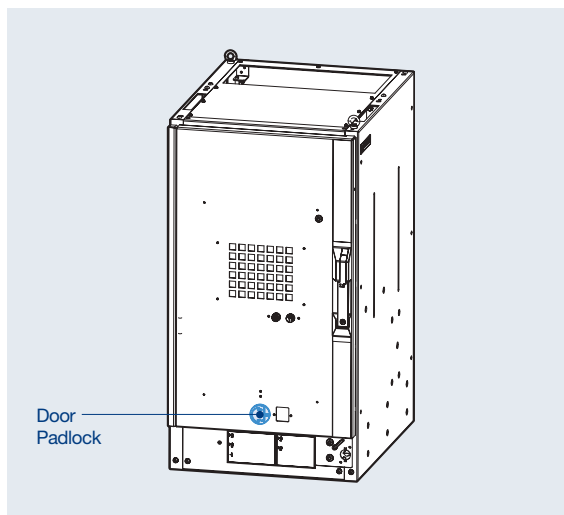

Charge interlock

Installed inside of a breaker as an option

VH-05/15 type

- In case the breaker is drawn-out when the closing spring is charged in the 'Disconnected' position, it prevents the complete withdrawal of the circuit breaker from the housing.

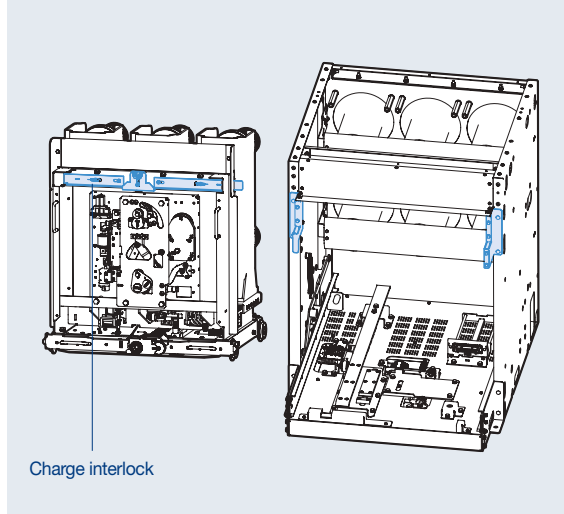

Mechanically operated cell switch (MOC)

Installed inside of a breaker as an option

VH-05/15 type

- This 6a6b switch indicates the 'ON' or 'OFF' condition of a VCB and is operated in the positions of 'Connected' and 'Test'.
- Below circuit diagram is based on 'OFF' status of VCB.

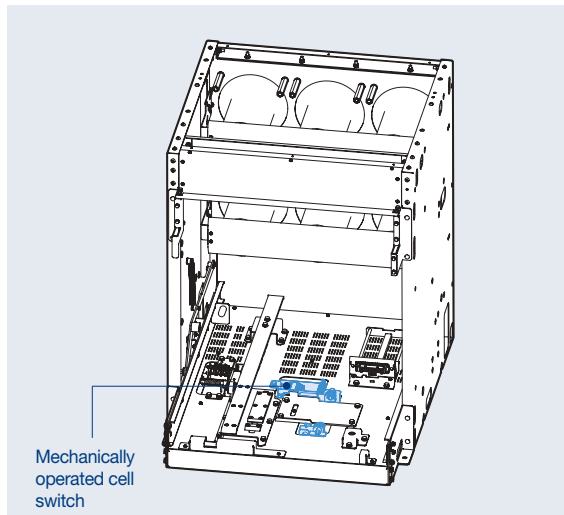
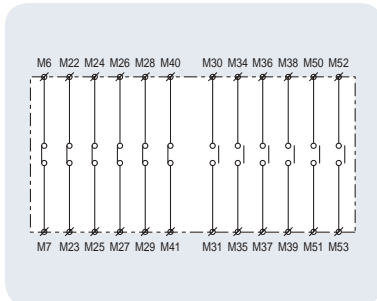

Accessory

Susol

Truck operated cell switch (TOC)

Built-in a cradle as an option

VH-05/15 type

- This 6a6b switch indicates the 'Connected' state of a VCB and is operated by the movement of a VCB frame. Below circuit diagram is based on 'Test' status of VCB.

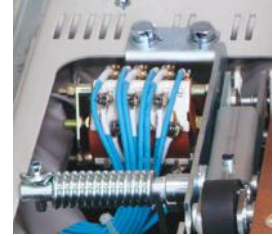
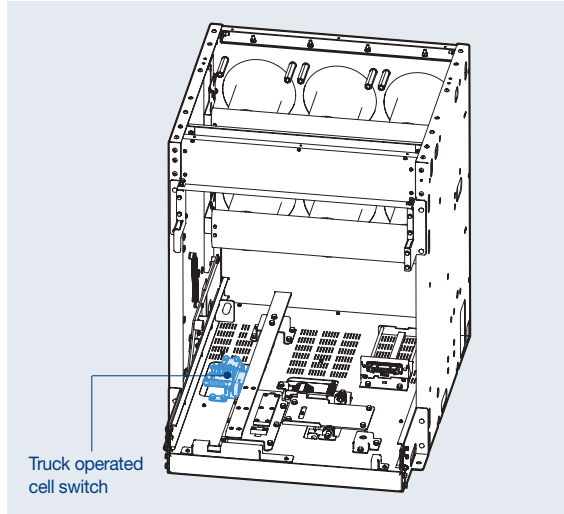
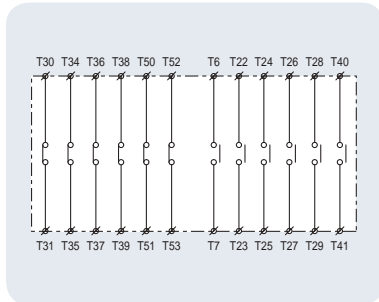

Auxiliary guide frame

- Auxiliary guide frame is provided in order to move safely 36/40.5kV breaker into the switchgear.
- It can be used in combination with the hand pallet which meets the requirement shown below.



Applicable hand pallet

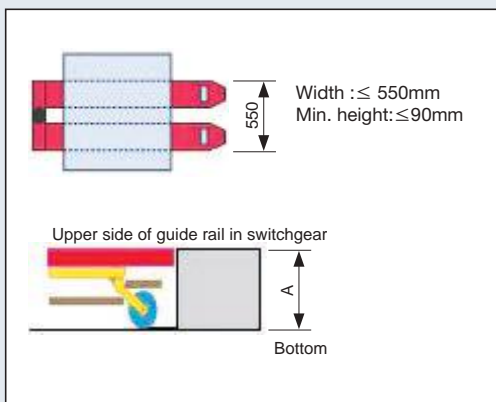

<Fig 1>



If dimension A in Fig. 1 is less than 120mm B type pallet can be used. In case of more than 120mm C type must be applied.

Control circuit diagram

Susol

UVL-05/15/27

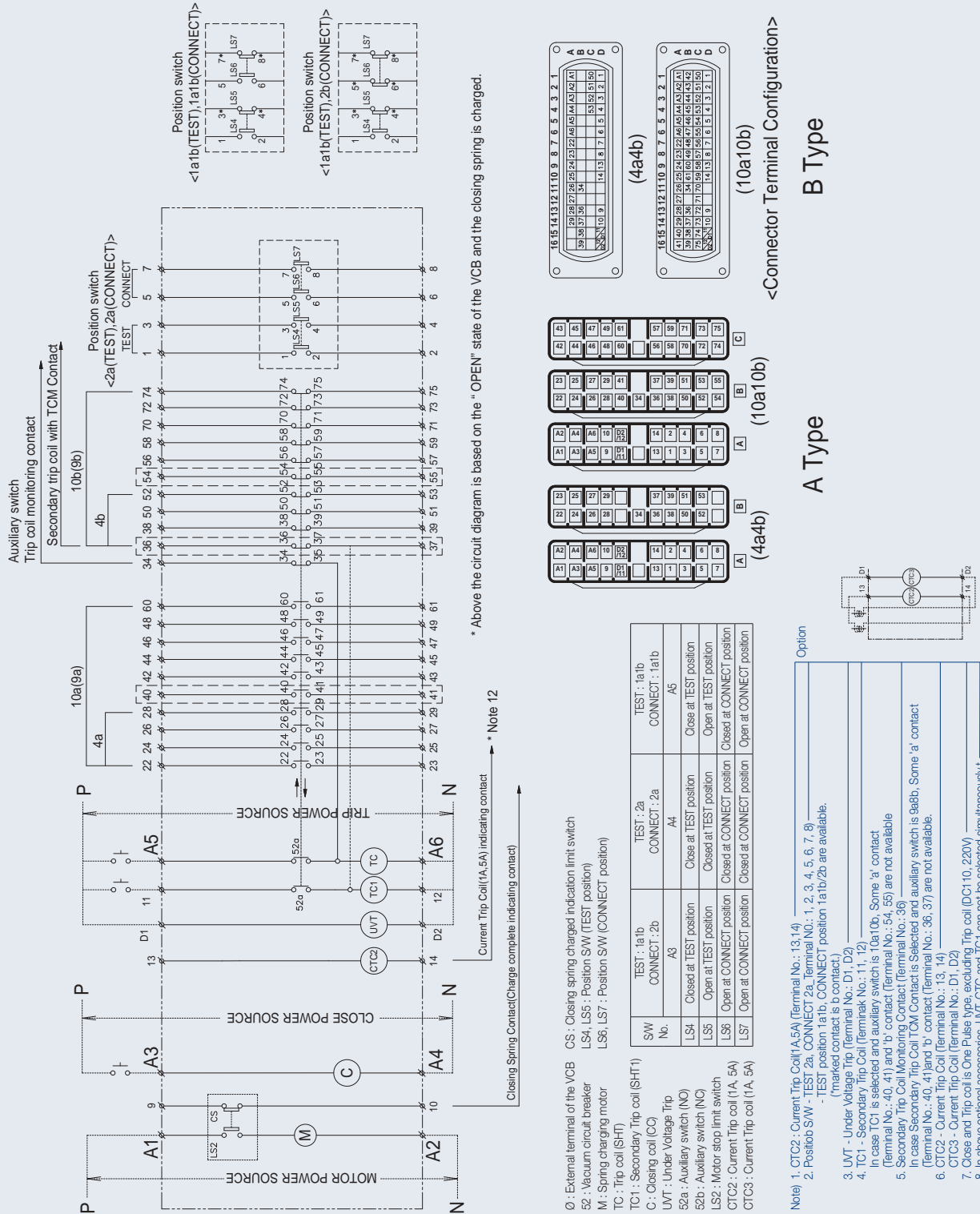

* Above the circuit diagram is based on the " OPEN " state of the VCB and the closing spring is charged.

* Note 12

Closing Spring Contact (Charge complete indicating contact)
Current Trip Coil (I.A, 5A) indicating contact

UVH-38

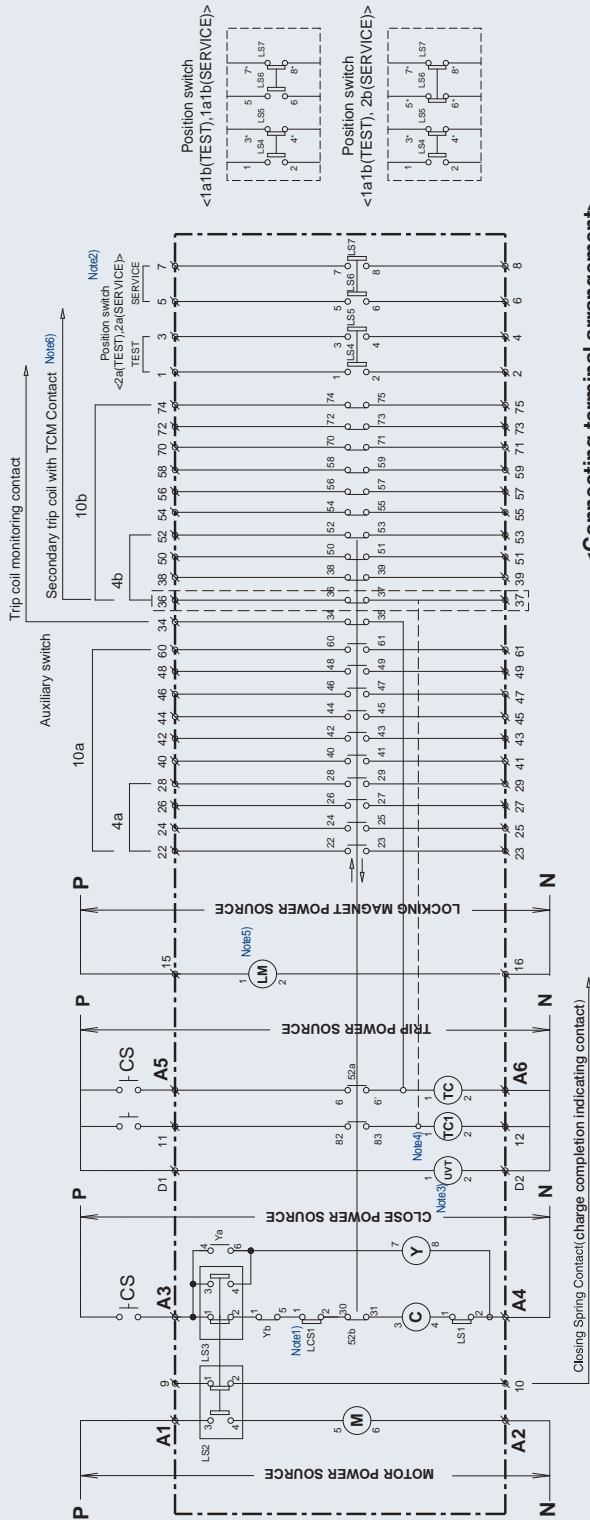

<Connecting terminal arrangement>

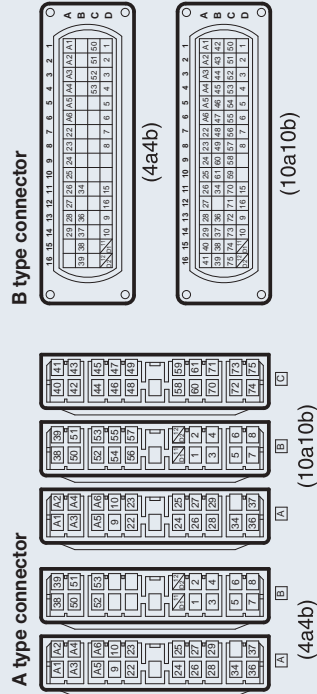
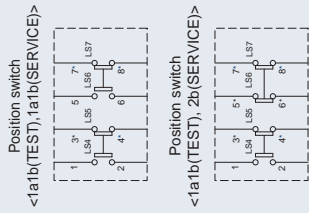

SW No.	TEST : 1a1b	TEST : 2a	TEST : 1a1b
A3	Close at TEST position	A4	SERVICE : 1a1b
A5	Close at TEST position	A5	SERVICE : 1a1b
A6	Close at TEST position		
A7	Close at TEST position		
A8	Close at TEST position		
A9	Close at TEST position		
A10	Close at TEST position		
A11	Close at TEST position		
A12	Close at TEST position		
A13	Close at TEST position		
A14	Close at TEST position		
A15	Close at TEST position		
A16	Close at TEST position		
A17	Close at TEST position		
A18	Close at TEST position		
A19	Close at TEST position		
A20	Close at TEST position		
A21	Close at TEST position		
A22	Close at TEST position		
A23	Close at TEST position		
A24	Close at TEST position		
A25	Close at TEST position		
A26	Close at TEST position		
A27	Close at TEST position		
A28	Close at TEST position		
A29	Close at TEST position		
A30	Close at TEST position		
A31	Close at TEST position		
A32	Close at TEST position		
A33	Close at TEST position		
A34	Close at TEST position		
A35	Close at TEST position		
A36	Close at TEST position		
A37	Close at TEST position		
A38	Close at TEST position		
A39	Close at TEST position		
A40	Close at TEST position		
A41	Close at TEST position		
A42	Close at TEST position		
A43	Close at TEST position		
A44	Close at TEST position		
A45	Close at TEST position		
A46	Close at TEST position		
A47	Close at TEST position		
A48	Close at TEST position		
A49	Close at TEST position		
A50	Close at TEST position		
A51	Close at TEST position		
A52	Close at TEST position		
A53	Close at TEST position		
A54	Close at TEST position		
A55	Close at TEST position		
A56	Close at TEST position		
A57	Close at TEST position		
A58	Close at TEST position		
A59	Close at TEST position		
A60	Close at TEST position		
A61	Close at TEST position		
A62	Close at TEST position		
A63	Close at TEST position		
A64	Close at TEST position		
A65	Close at TEST position		
A66	Close at TEST position		
A67	Close at TEST position		
A68	Close at TEST position		
A69	Close at TEST position		
A70	Close at TEST position		
A71	Close at TEST position		
A72	Close at TEST position		
A73	Close at TEST position		
A74	Close at TEST position		
A75	Close at TEST position		
A76	Close at TEST position		
A77	Close at TEST position		
A78	Close at TEST position		
A79	Close at TEST position		
A80	Close at TEST position		
A81	Close at TEST position		
A82	Close at TEST position		
A83	Close at TEST position		
A84	Close at TEST position		
A85	Close at TEST position		
A86	Close at TEST position		
A87	Close at TEST position		
A88	Close at TEST position		
A89	Close at TEST position		
A90	Close at TEST position		
A91	Close at TEST position		
A92	Close at TEST position		
A93	Close at TEST position		
A94	Close at TEST position		
A95	Close at TEST position		
A96	Close at TEST position		
A97	Close at TEST position		
A98	Close at TEST position		
A99	Close at TEST position		
A100	Close at TEST position		

- 0: External terminal of VCB
- 52: Vacuum circuit breaker
- M: Spring charging motor
- TC: Trip coil
- TC1: Secondary trip coil
- C: Close coil
- Y: Anti-pump relay
- UVT: Under voltage trip
- 52a: Auxiliary switch (a)
- 52b: Auxiliary switch (b)
- LS1: Close interlock limit switch (only withdrawable type)
- LS2: Motor stop, close spring charged indication limit switch
- LS3: Anti-pumping limit switch
- LCS1: Trip latch checking switch (preventing closing unless the trip latch is properly reset)
- LS4, LS5: Position SW (close in TEST position)
- LS6, LS7: Position SW (close in SERVICE position)

- Note)
- LCS1 : Latch Checking Switch
 - Position SW - TEST 2a, SERVICE 2a(Terminal No. 1, 2, 3, 4, 5, 6, 7, 8) 1a1b at TEST position and 1a1b at SERVICE position are also available. (In case of 1a1b "marked contact is b - normally open contact)
 - UVT - Under Voltage Trip (Terminal No. D1, D2)
 - TC1 - Secondary Trip Coil (Spare trip coil, terminal No. 11, 12)
 - LM - Locking Magnet (Terminal No. 15, 16). Type H only withdrawable type.
 - Secondary Trip Coil monitoring contact (Terminal No. 36) b contact(36, 37) is not available if Trip Coil monitoring contact is applied to Secondary Trip Coil.
 - Above options TC1 and UVT can not be used simultaneously.
 - LS1 (closing-interlock Limit-switch) is not available for fixed version
 - Above circuit diagram is based on "OFF" status of VCB and closing spring is charged.
 - Please make sure that keep the direction of P, N on this circuit diagram.

Control circuit diagram

Susol

VH-05/15

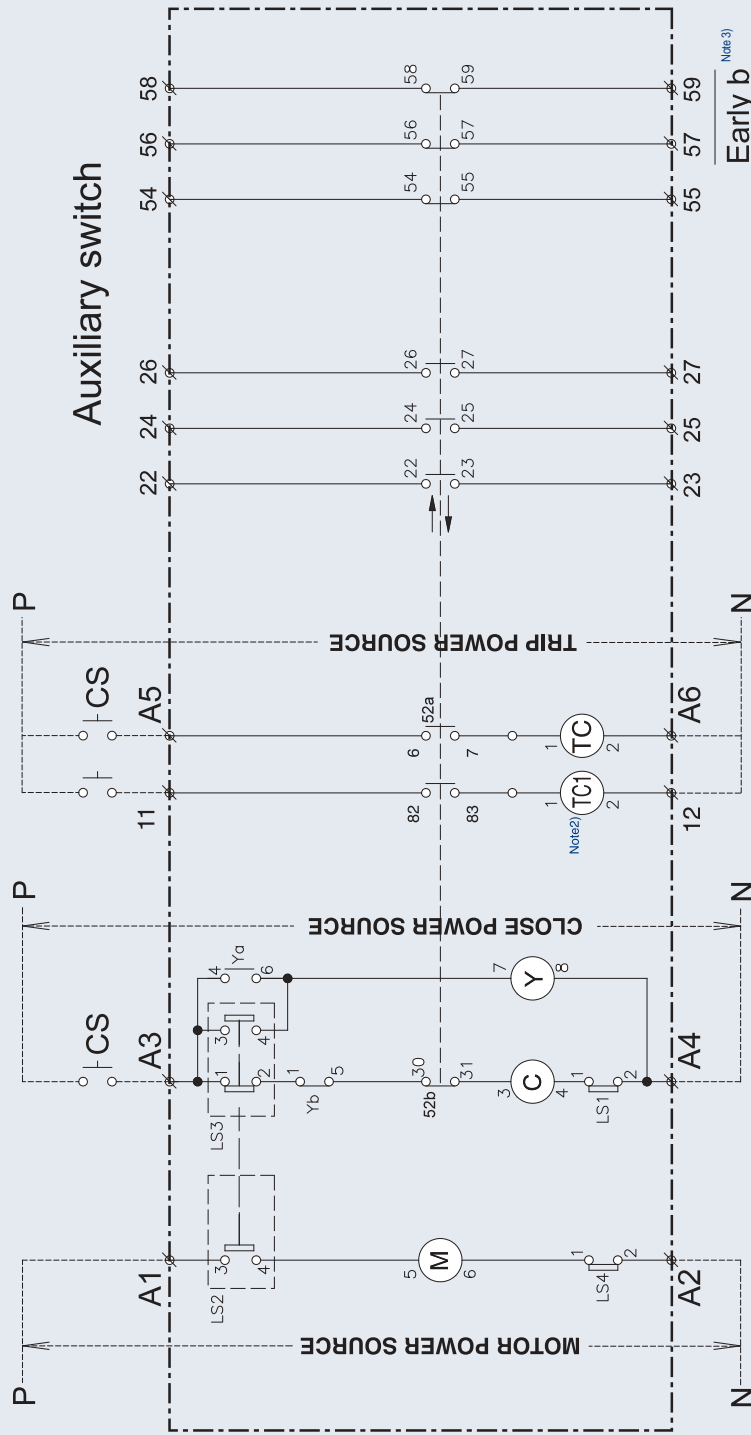

Early b

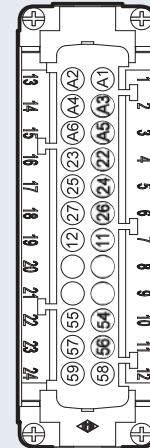
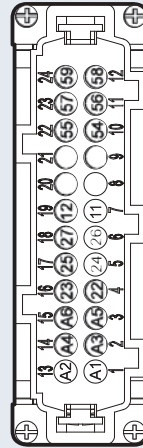

- ∅ : External terminal of VCB
- 52 : Vacuum circuit breaker
- M : Spring charging motor
- TC : Trip coil
- TC1 : Secondary trip coil(Optional)
- C : Closing coil
- Y : Anti-pump relay
- 52a : Auxiliary switch (NO)
- 52b : Auxiliary switch (NC)
- LS1 : Close interlock limit switch
- LS2 : Motor stopping limit switch
- LS3 : Anti-closing, Anti-pumping limit switch
- LS4 : Motor charging interlock limit switch

- Note) 1. Above circuit diagram is based on 'OFF' status of VCB and closing spring is charged.
 2. TC1(Optional) - Secondary Trip Coil(Spare trip coil, terminal No.11, 12)
 3. Two(2) Early b' auxiliary contact is provided (Terminal No.56-57, 58-89)
 4. Please follow direction of P-N marked in the above circuit diagram.

4.76/15kV, 25/31.5kA, 1200A

Withdrawable (H type unit, phase distance 150mm)

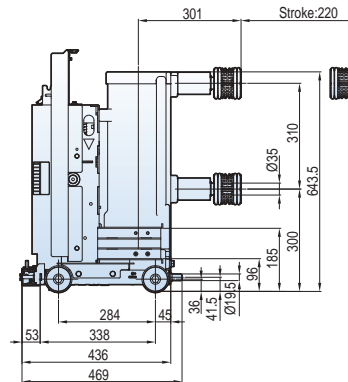
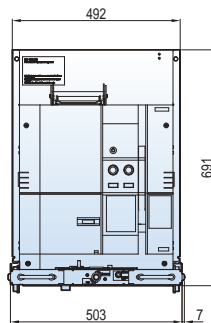
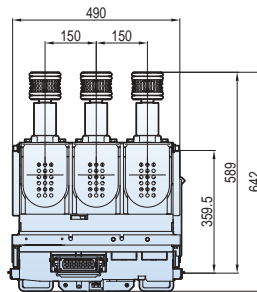

* Ha, Hf type cradle applied

4.76/15kV 25/31.5kA 1200A

Withdrawable (H type unit, phase distance 210mm)

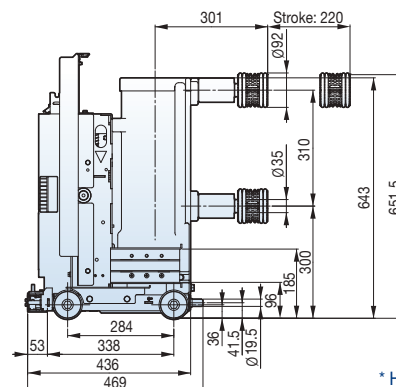
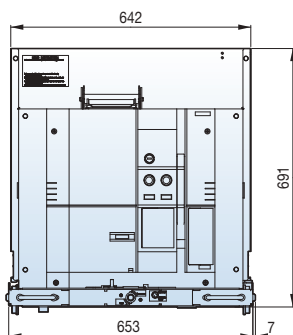
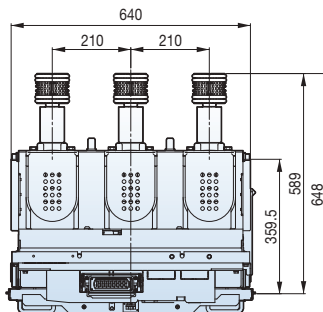

* Hf type cradle applied

4.76/15kV, 25/31.5kA, 2000A

Withdrawable (H type unit, phase distance 210mm)

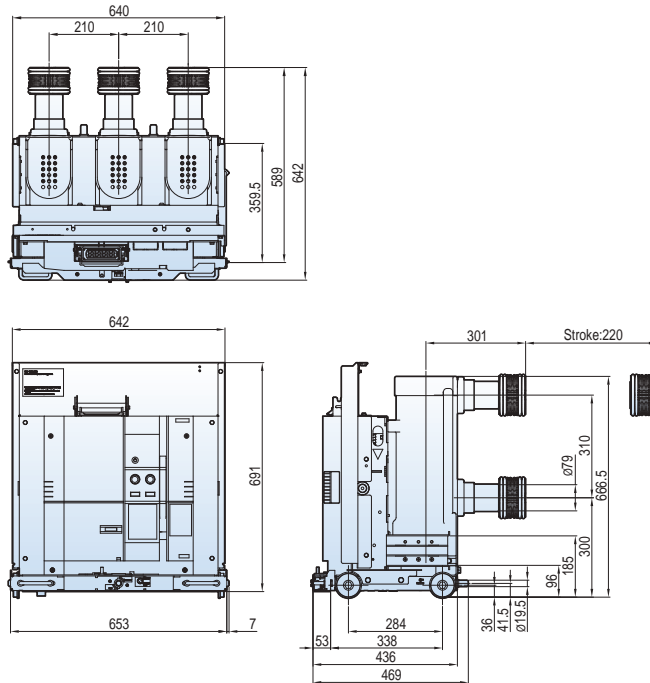

* He type cradle applied

4.76/15kV 25/31.5kA 2000A

Withdrawable (H type unit, phase distance 210mm)

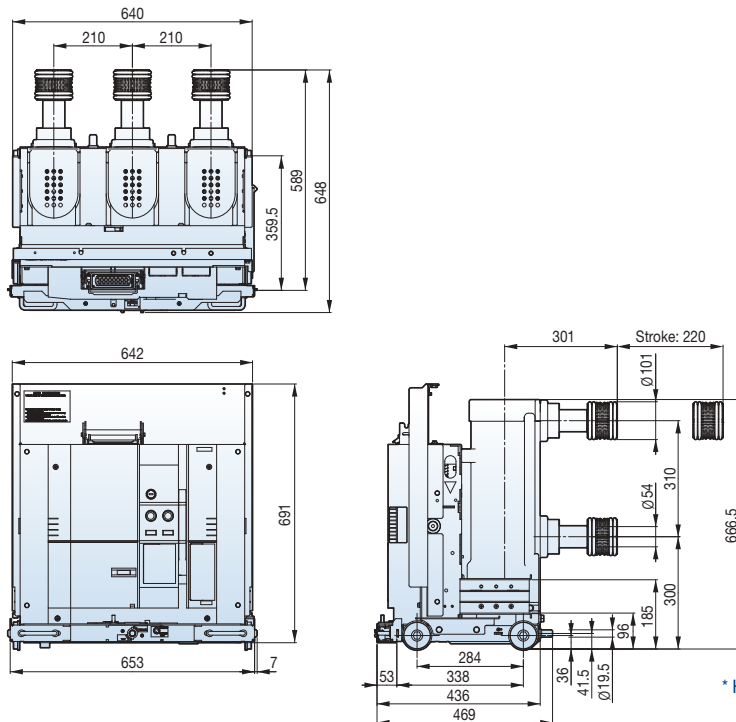

* Ha, Hf type cradle applied

Dimensions

Susol

4.76kV, 25/31.5kA, 1200A

Fixed (P type, Phase distance 150mm)

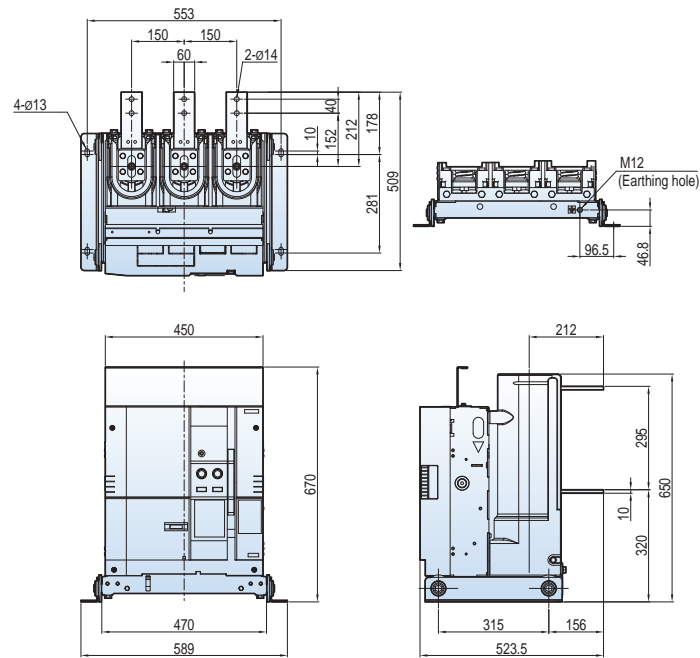

15kV, 25/31.5kA, 1200A

Fixed (P type, Phase distance 150mm)

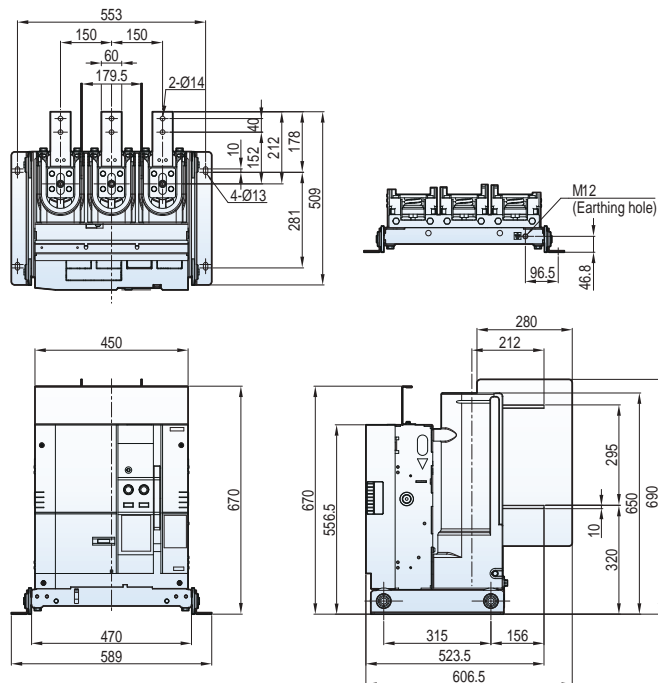

4.76/15kV 25/31.5kA 1200A
Fixed (P type, Phase distance 210mm)

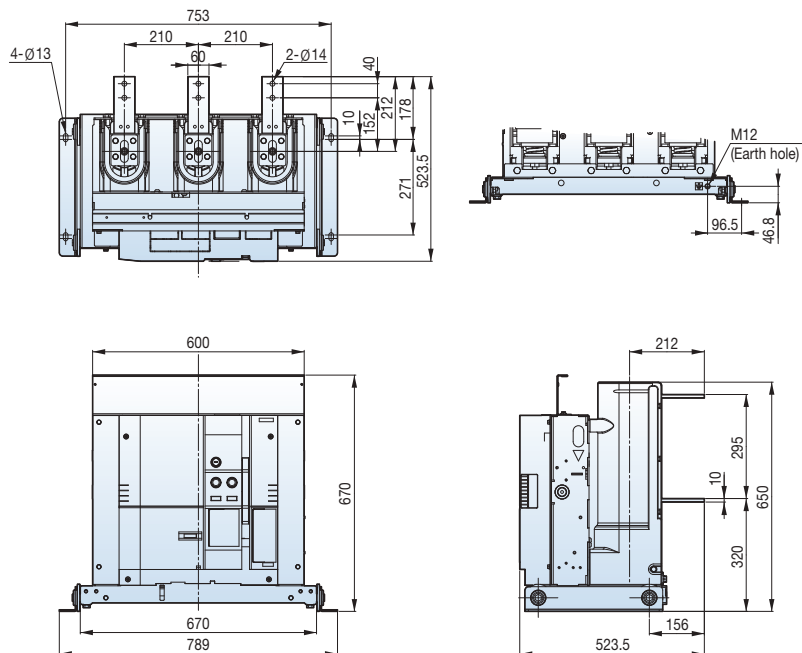

4.76/15kV 25/31.5kA 1200A
Fixed (P type, Phase distance 254mm)

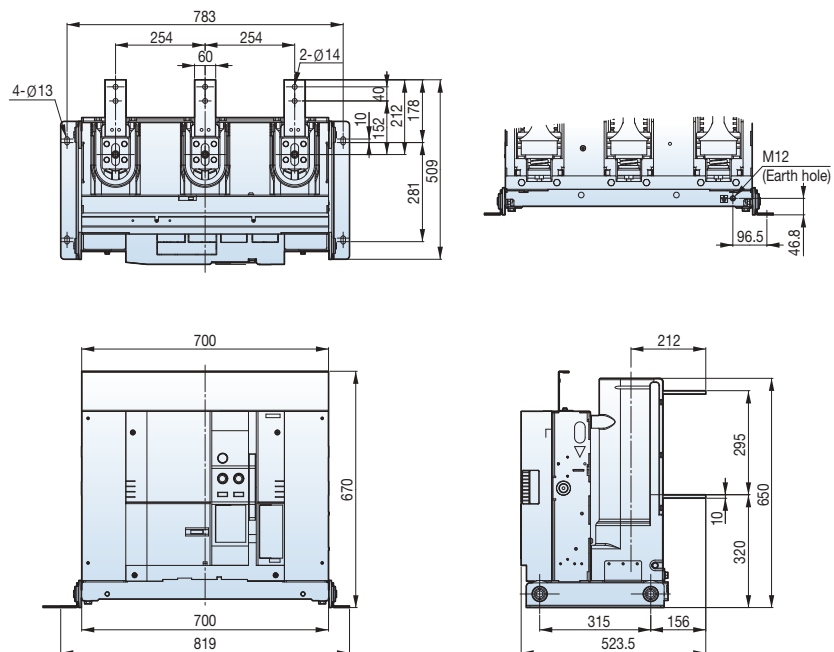

Dimensions

Susol

4.76/15kV 25/31.5kA 2000A

Fixed (P type, Phase distance 150mm)

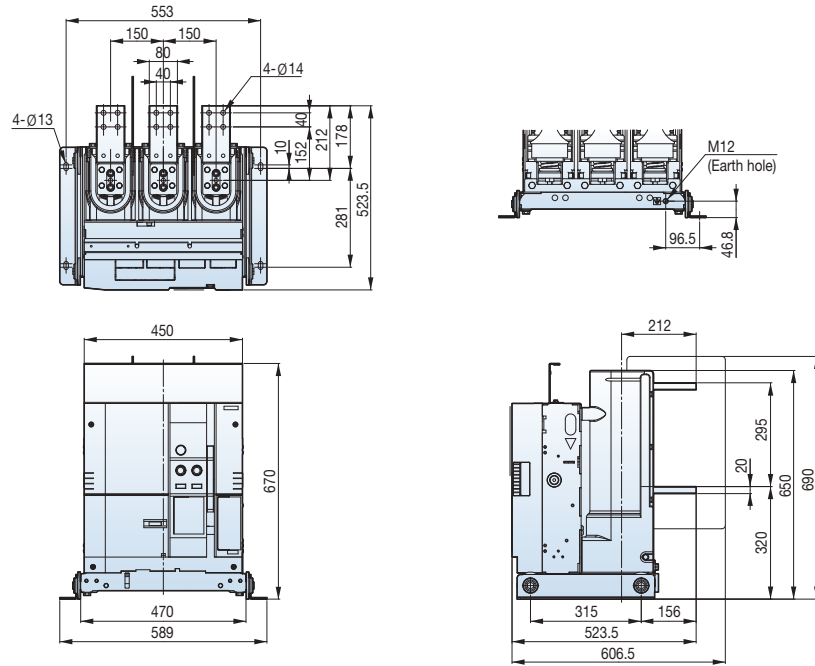

4.76kV, 25/31.5kA, 2000A

Fixed (P type, Phase distance 210mm)

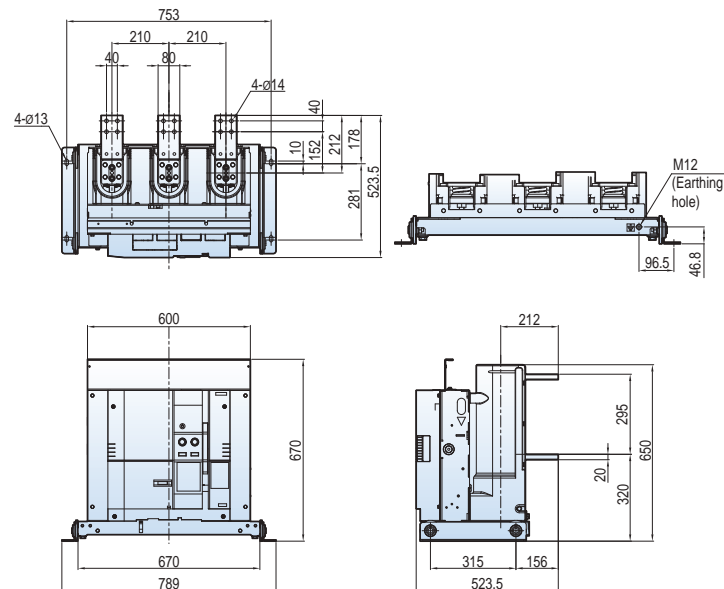

15kV, 25/31.5kA, 2000A
Fixed (P type, Phase distance 210mm)

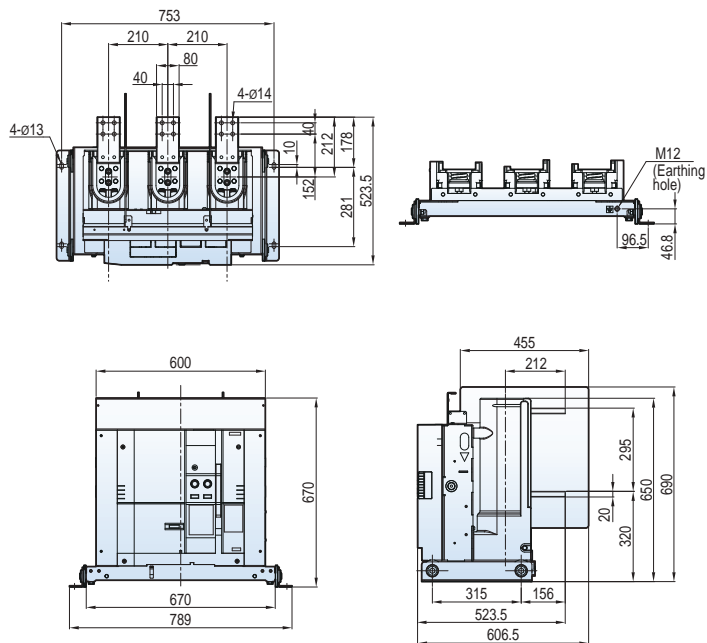

4.76/15kV, 25/31.5kA, 2000A
Fixed (P type, Phase distance 254mm)

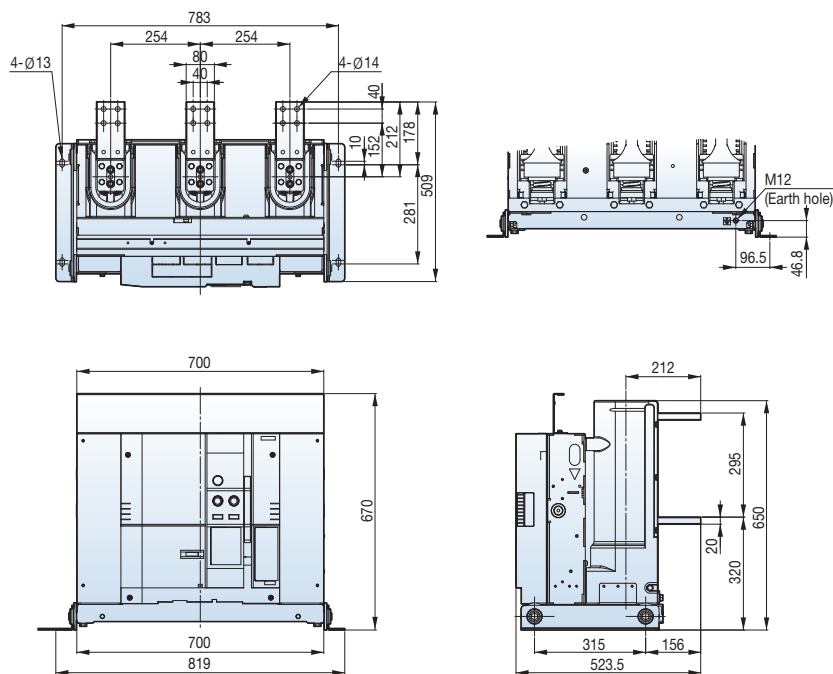

Dimensions

Susol

27kV 25kA 1200A

Fixed (P type, Phase distance 254mm)

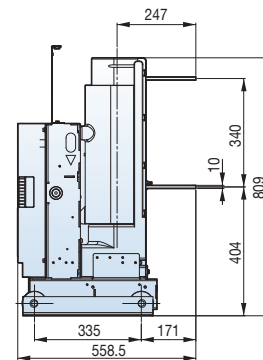
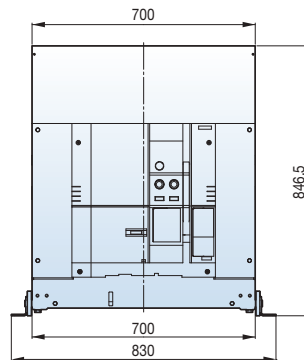
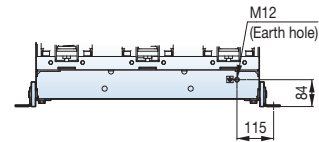
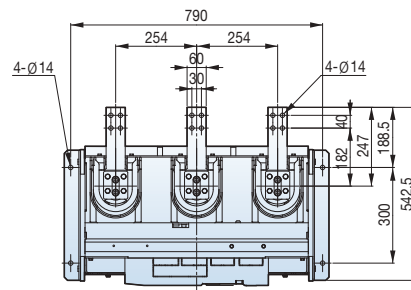

4.76/15kV 25/31.5kA 1200A

Withdrawable (Ha type cradle, phase distance 150mm)

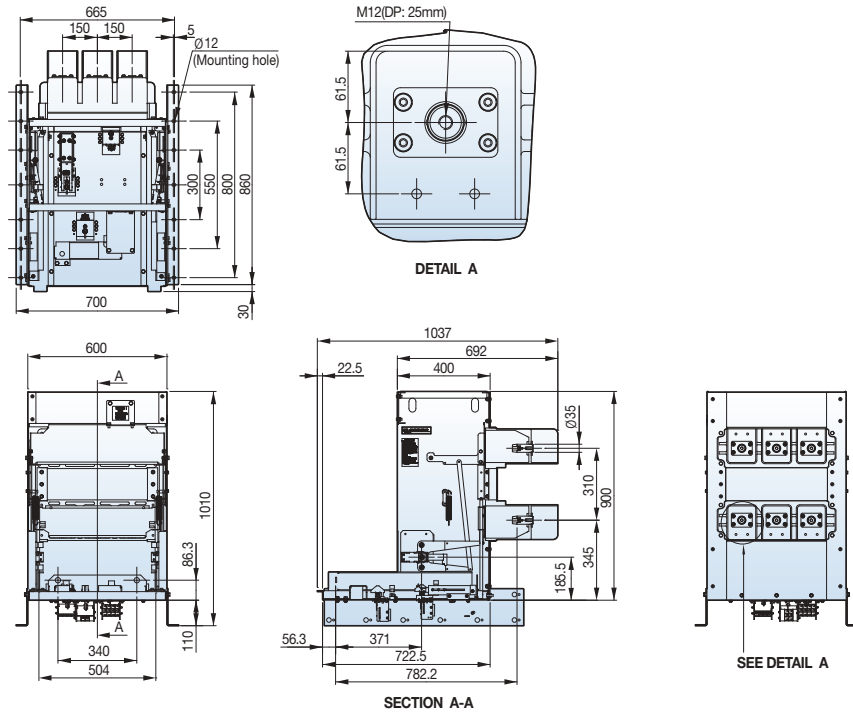

4.76/15kV 25/31.5kA 2000A

Withdrawable (Ha type cradle, phase distance 210mm)

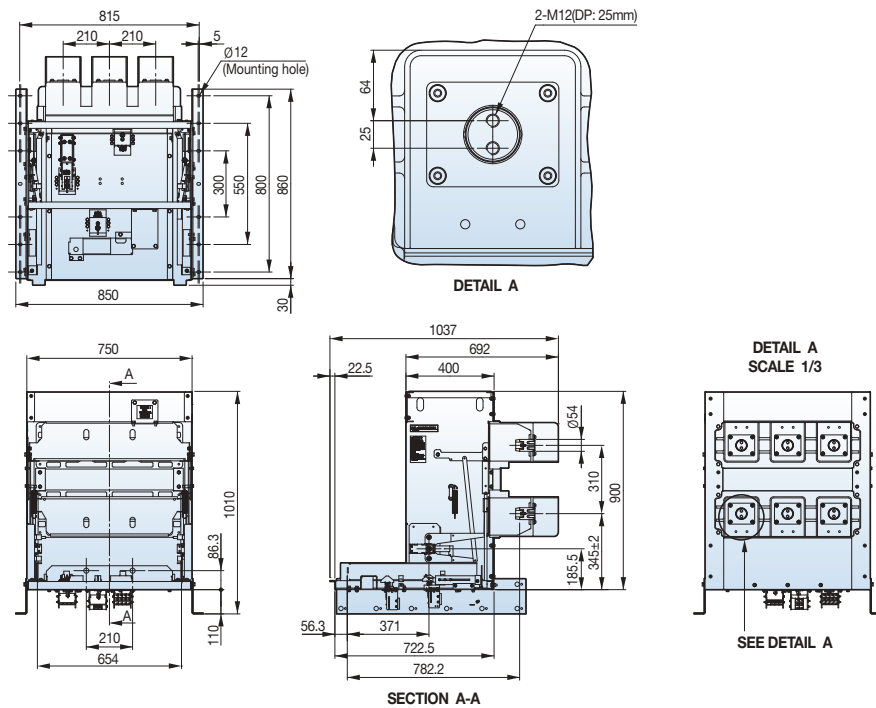

Dimensions

Susol

4.76/15kV 25/31.5kA 1200A

Withdrawable (He type cradle, Arc, phase distance 150mm)

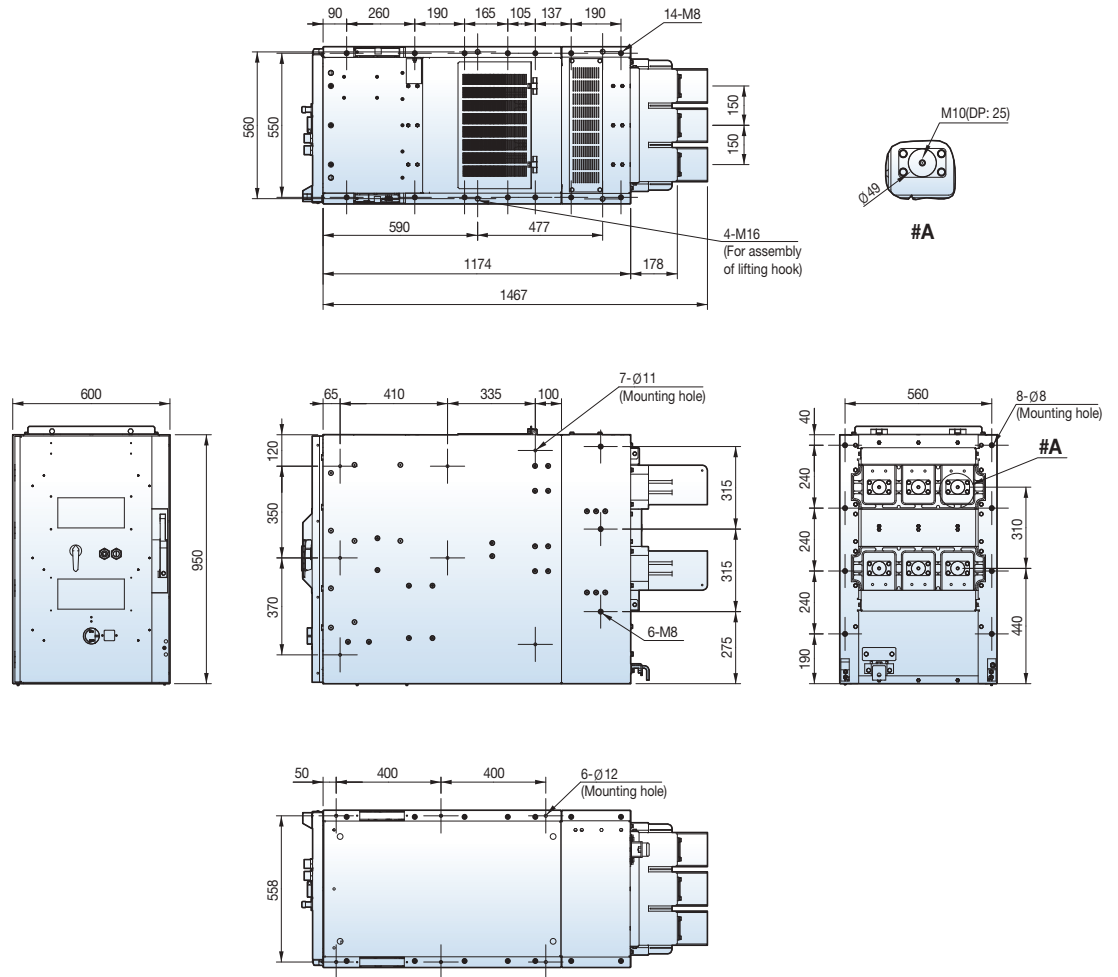

4.76/15kV 25/31.5kA 1200A

Withdrawable (He type cradle, Arc, phase distance 210mm)

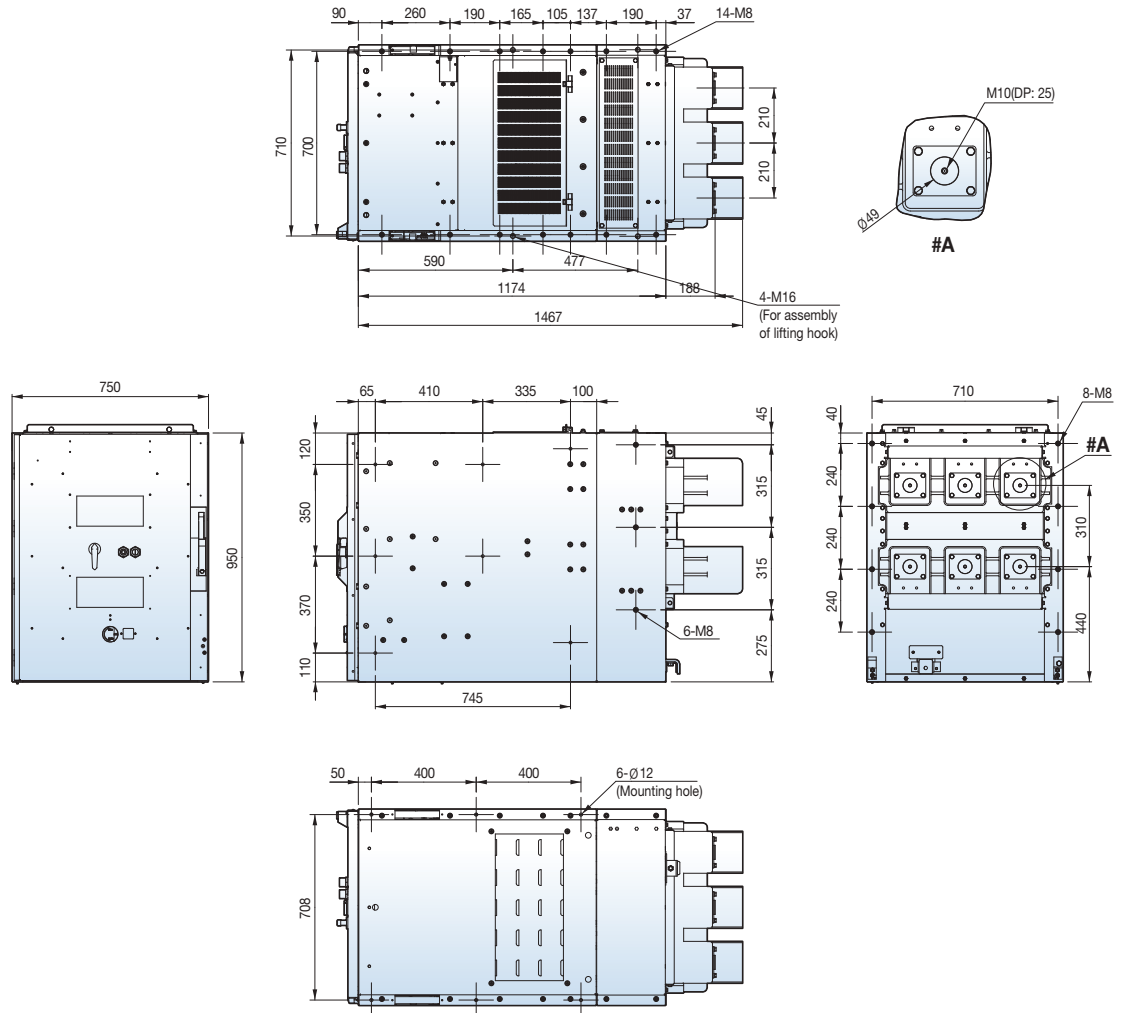

Dimensions

Susol

4.76/15kV 25/31.5kA 2000A

Withdrawable (He type cradle, Arc, phase distance 210mm)

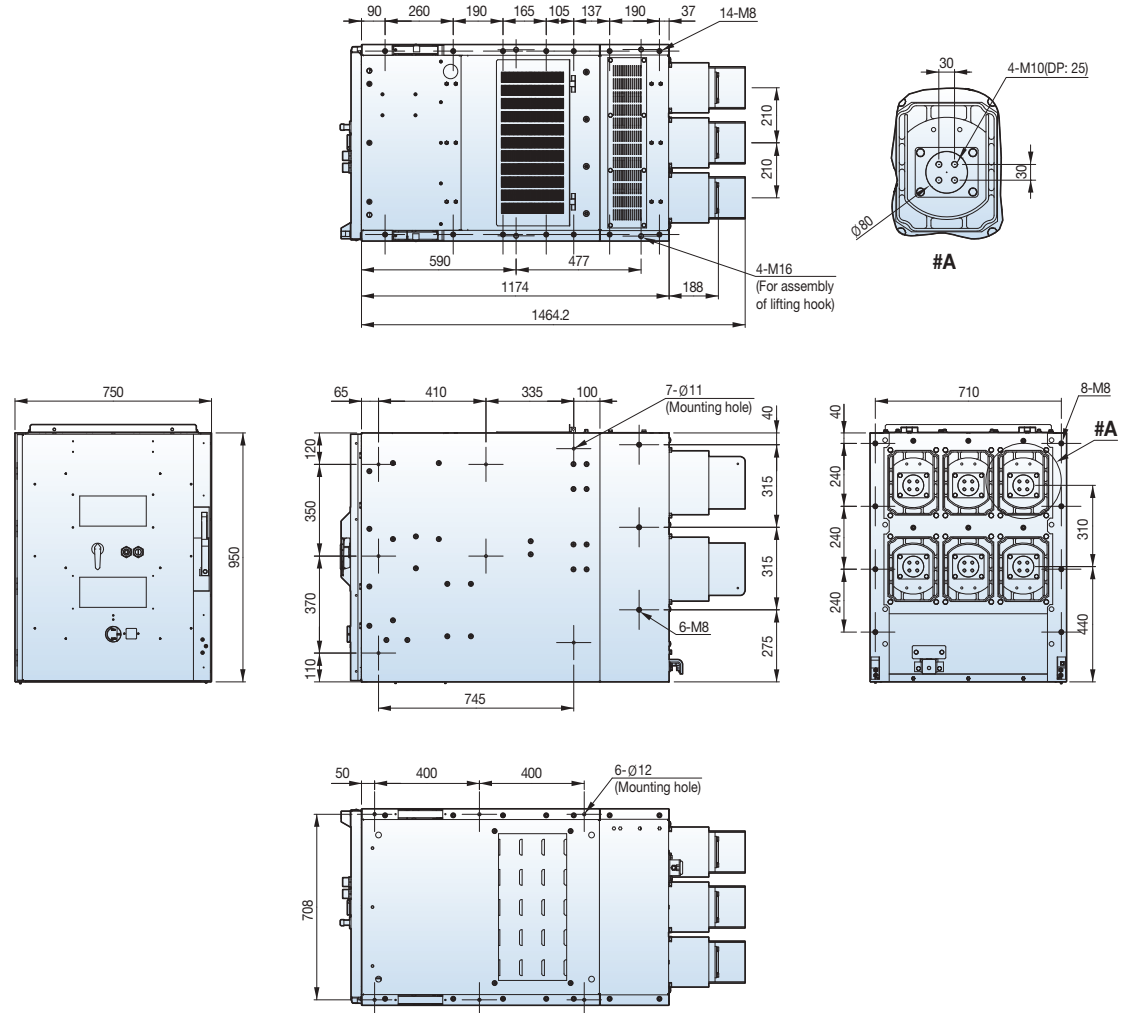

4.76/15kV 25/31.5kA 1200A

Withdrawable (Hf type cradle, Non-Arc , phase distance 210mm)

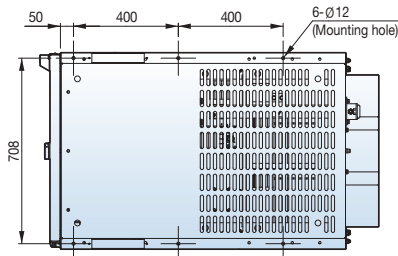
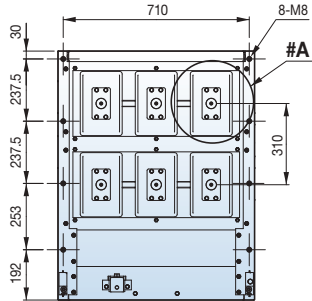
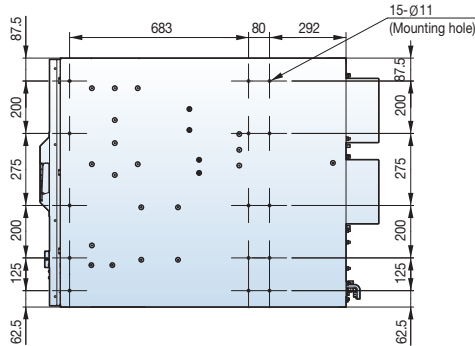
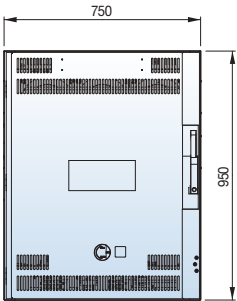
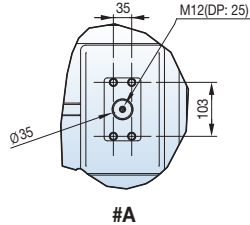
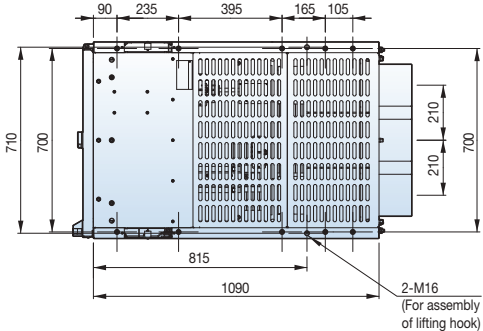

4.76/15kV 25/31.5kA 2000A

Withdrawable (Hf type cradle, Non-Arc , phase distance 210mm)

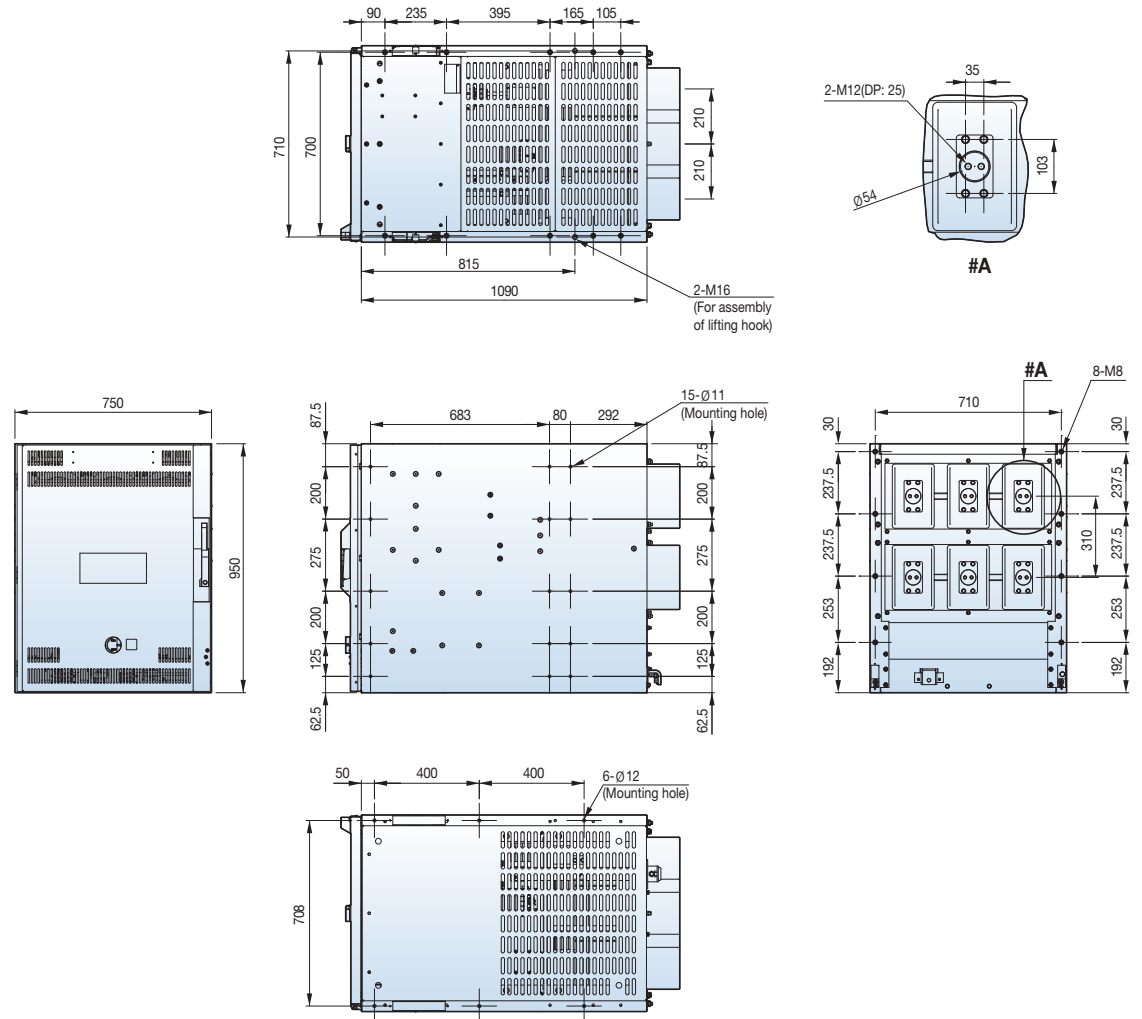

38kV 31.5/40kA 1200/2000A

Fixed (P type, Phase distance 300mm)

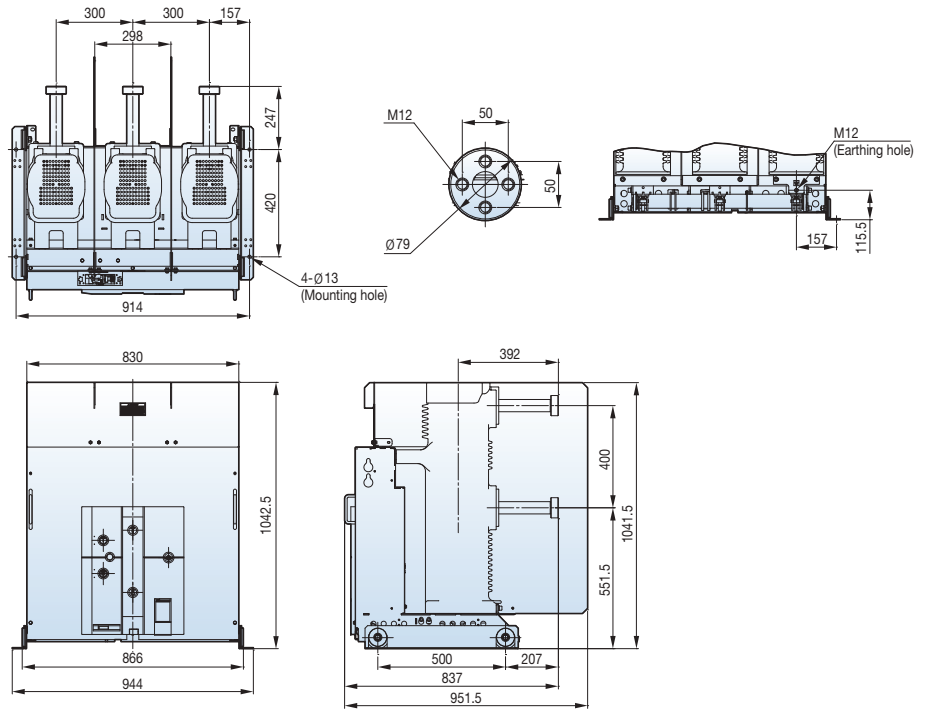

Withdrawable (H type unit, phase distance 300mm)

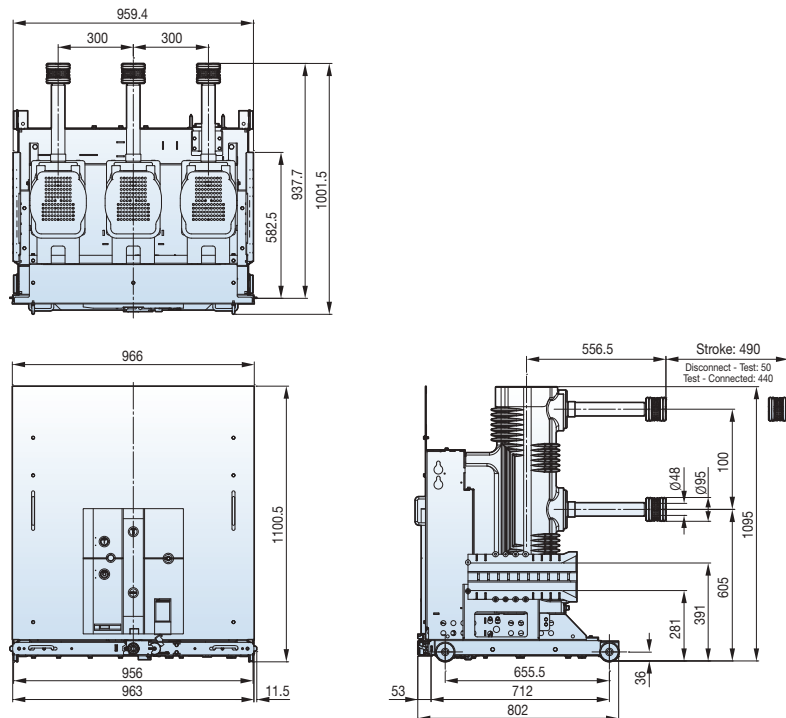

38kV 31.5/40kA 1200/2000A

Withdrawable (H type cradle, phase distance 300mm)

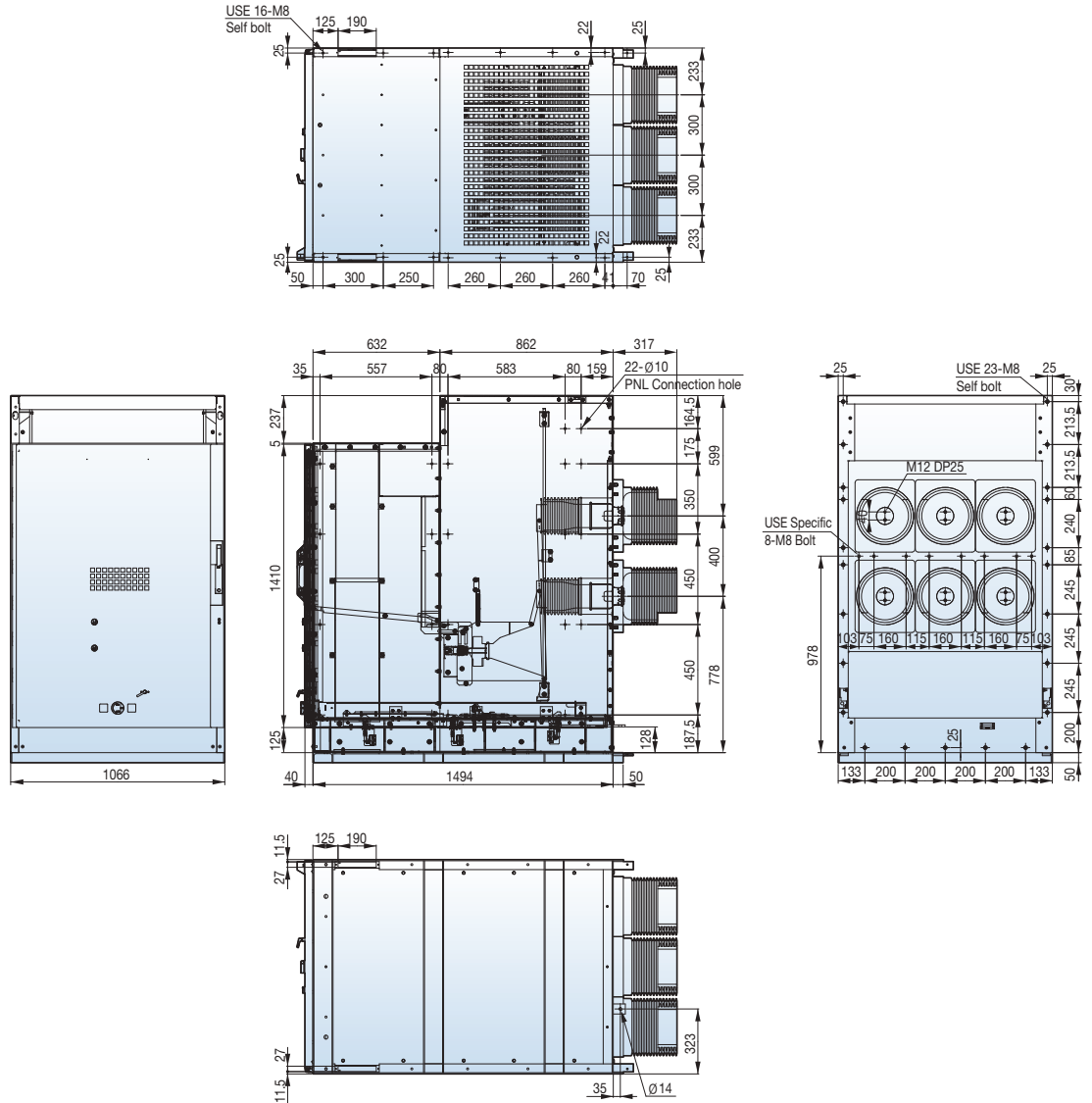

Dimensions

Susol

4.76/15kV, 40/50kA, 1200/2000A

Withdrawable (Ha type cradle, phase distance 254mm)

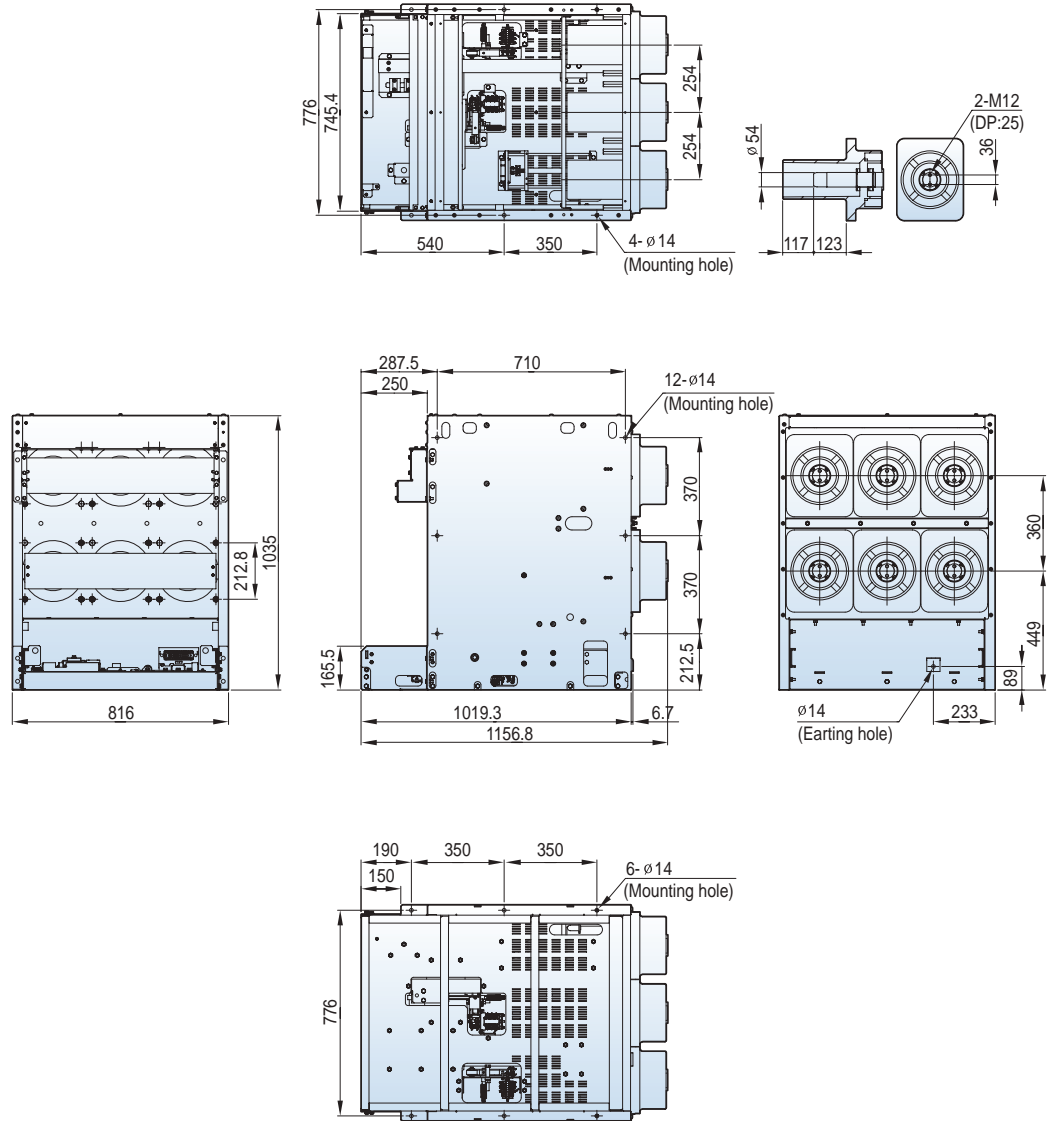

4.76/15kV, 40/50kA, 3000A

Withdrawable (Ha type cradle, phase distance 254 mm)

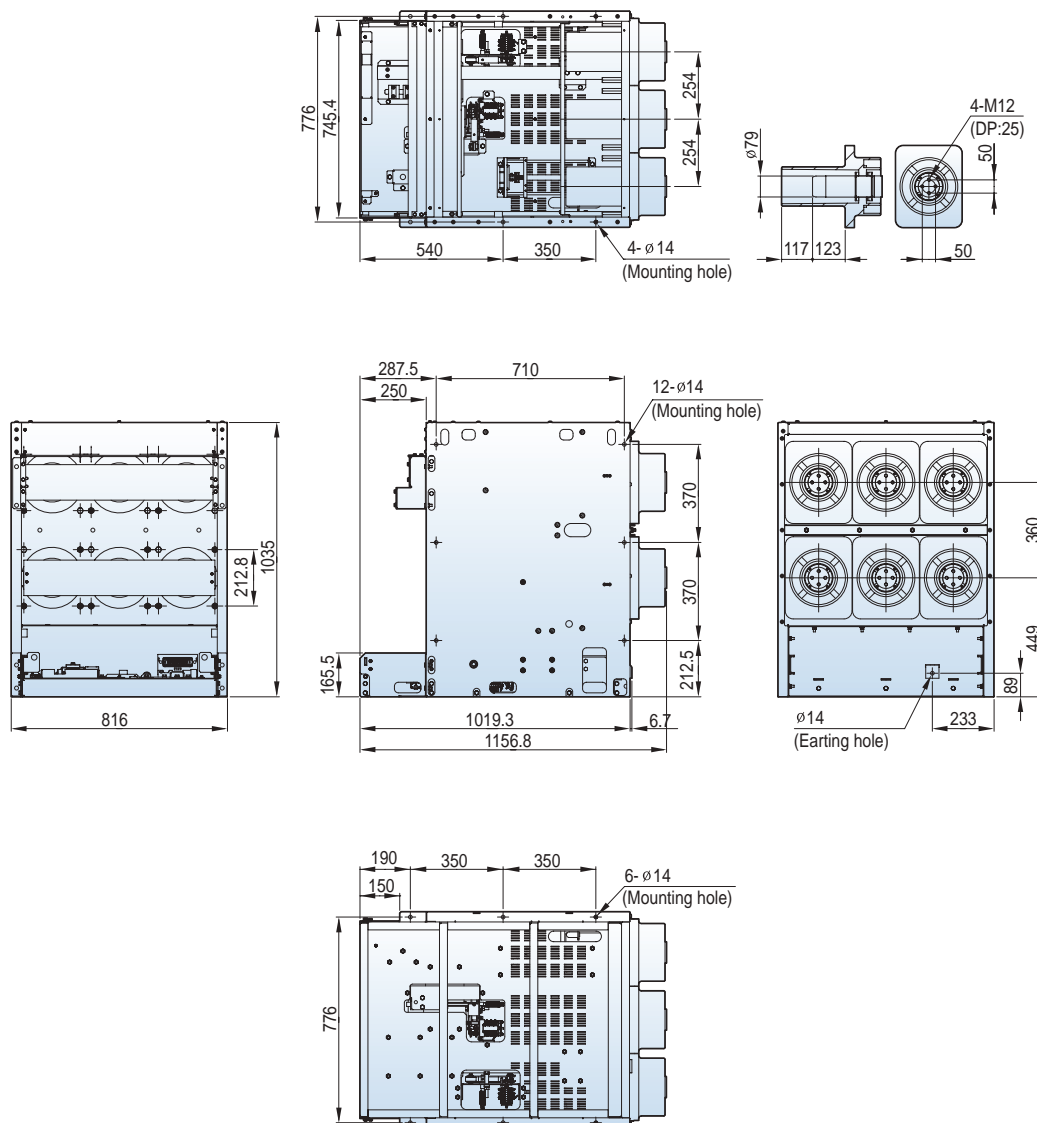

Electrical endurance by interrupting current

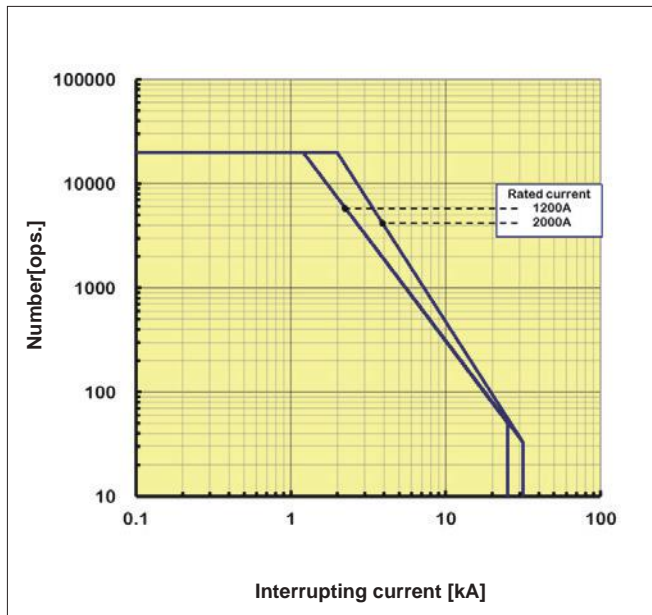

VI model LV6 at 5/15kV

- N : Operation numbers
- I : Interrupting current

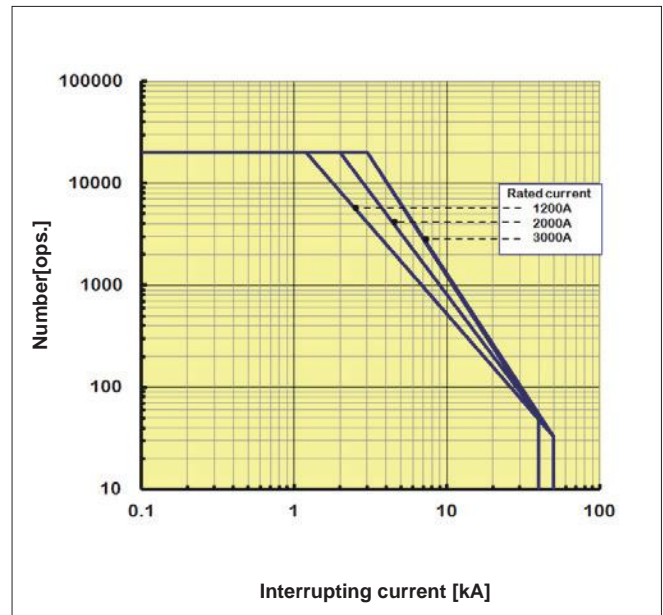

VI model LV8 at 5/15kV

- N : Operation numbers
- I : Interrupting current

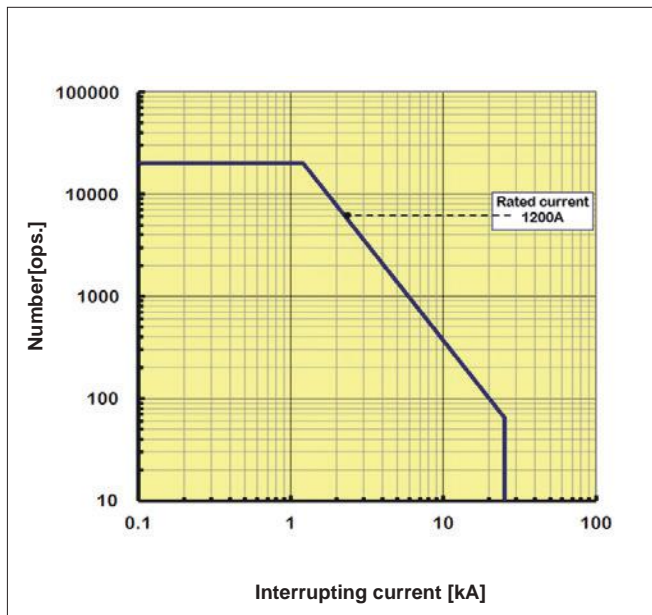

VI model LV14-P1 at 27kV

- N : Operation numbers
- I : Interrupting current

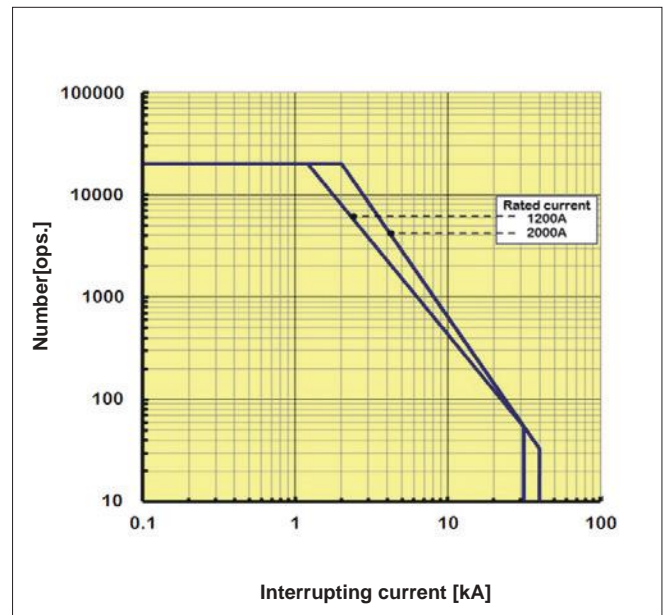

VI model LV8-P at 38kV

- N : Operation numbers
- I : Interrupting current

Note) 1. Above graphs represent the characteristics of the electrical life of LS Susol VCB.
 2. Life characteristics of each model in each rating represents the LOG-LOG graphs.

Standard Use Environment for Susol VCB

The operation characteristic of Vacuum Circuit Breaker such as insulation and endurance is often influenced largely by external environment and thus should be applied appropriately with conditions of the place where it is used taken into consideration.

The following values are the limits have been set in accordance with IEC 62271-100 (IEC 62271-1)

Ambient Temperature

- maximum temperature: +40°C
- 24-hour average maximum temperature: +35°C
- minimum temperature: -5°C

Altitude

- 1000m or less above sea level

Relative Humidity

- 24 hours average value: 95% or less
- One month average: 90% or less

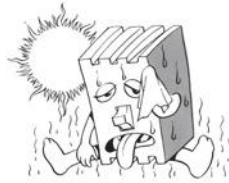

- If a standard circuit breaker is used in high temperature exceeding 40°C, you are advised to use it according to the current corrected for each level of ambient temperature in catalog.
- If used in conditions of high humidity, the dielectric strength or electric performance may be degraded.

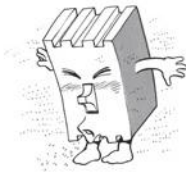

- It is highly recommended to use a dust cover or anti-humid agent if it is used in dusty and humid conditions.
- Excessive vibration may cause a trip breaker such as connection fault or flaw on mechanical parts.



- If it is left ON or OFF for a long time, it is recommended to switch load current on a regular basis.
- It is recommend to put it in the sealed protection if corrosive gas is prevalent.

Special Use Environment

The circuit breaker is designed for use in standard use environment specified in Section 2. 1 of IEC62271-1. Concerning the special use environments as below the special use conditions are required to be considered, thus please contact us in advance.

- where altitude and ambient temperature are out of standard use environment. (-40°C)
- where a strong sea breeze blows
- when usually used in a humid place
- where a lot of steam or oil steam exists
- where explosive, flammable and other harmful gases might permeate the breaker
- In a dusty place
- where abnormal vibration or shock exists
- where a lot of ice and snow exist
- other special conditions

Withstand voltage compensation according to altitude

If the breaker is used in areas of sea level higher than 1000m the degradation of insulation performance should be taken into consideration.

70	36	170
50(65)	24	125
38	17.5	95
28(42)	12	75(82)
20	7.2	60
Ud [kV/1min]	Ur[kV]	Up [kV/1.2 × 50 μs]
Power Frequency Withstand Voltage		Impulse Withstand Voltage

<Table 1> Criteria of withstand voltages by rated voltages specified in IEC62271-1

Special Use Environment

Withstand voltage compensation according to altitude

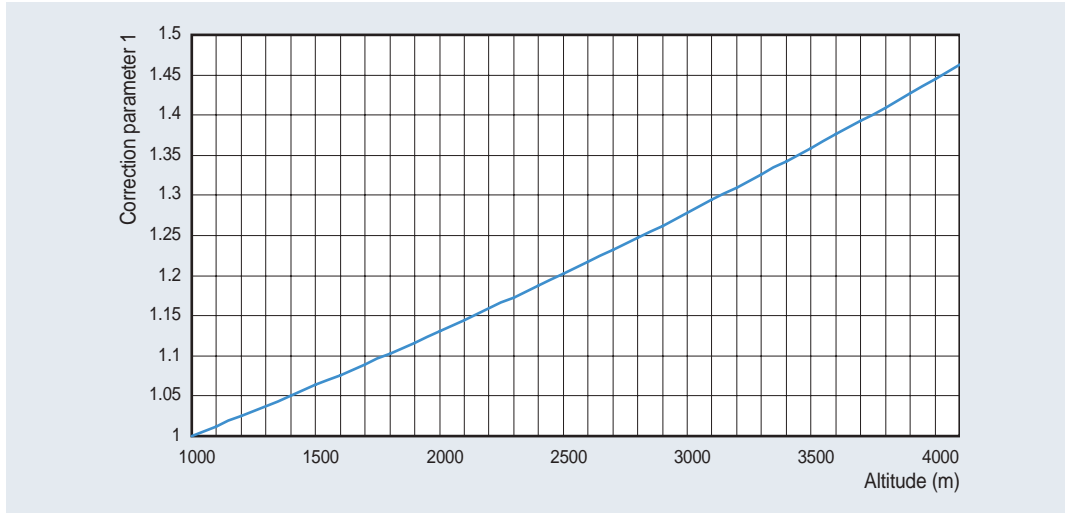

<Fig.1 > withstand voltage correction parameter 1 by altitude (based on a required withstand voltage)

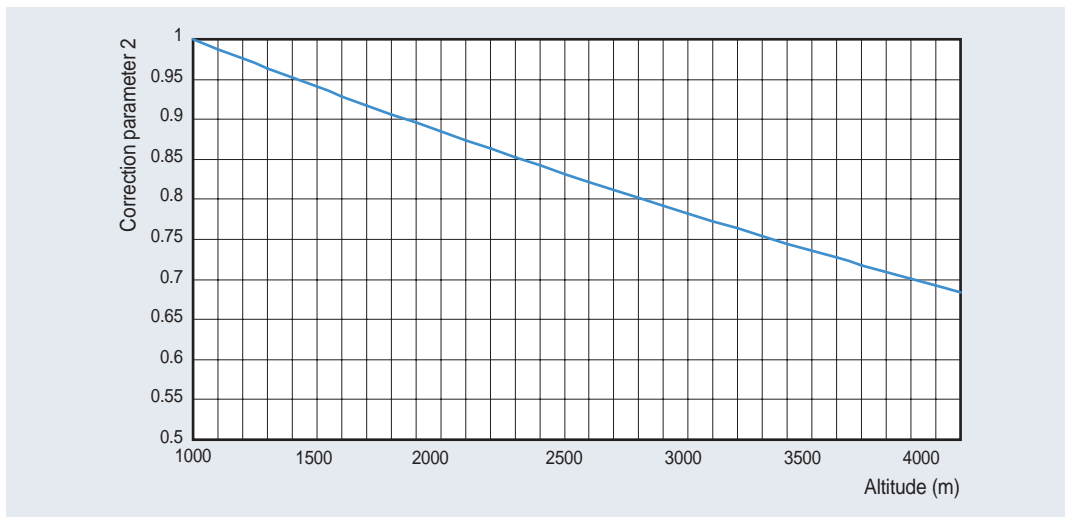

<Fig.2 > withstand voltage correction parameter 2 by altitude (based on a applicable withstand voltage)

Ex) Selecting a breaker to be used in a place of 2500m above sea level with a rated voltage 7.2kV (correction parameter 1 applied)

- correction parameter at 2500m is 1.2
- criteria of withstand voltage by rated voltage:
Power Frequency Withstand Voltage (Ud) = 20kV, Impulse Withstand Voltage (Up) = 60kV
- requirements withstand voltage criteria:
Power Frequency Withstand Voltage (Ud) = 20 × 1.2 = 24kV, Impulse Withstand Voltage (Up) = 72kV
Therefore rated voltage 12kV breaker shall apply to satisfy the required withstand voltage.

Ex) To apply a breaker with a rated voltage 12kV to the place of 2,500m above sea level (correction parameter 2 applied)

- correction parameter at 2500m is 0.825
- dielectric strength of VCB : Power Frequency Withstand Voltage (Ud) = 28 × 0.825 = 23.1kV, Impulse Withstand Voltage (Up) = 75 × 0.825 = 62kV/1.2 × 50 μs
Therefore above breaker with rated voltage 12kV shall apply to rated voltage system 7.2kV at the altitude.

Rated current compensation in accordance with ambient temperature

When normal ambient temperature exceeds the temperature specified in the environment the following formula help to select the applicable current.

$$I_a = I_r \left(\frac{\Theta_{\max} - \Theta_a}{\Theta_r} \right)^{1/2}$$

- I_a : allowable continuous current in the actual ambient temperature Θ_a
- I_r : rated current at 40 °C ambient temperature
- Θ_{\max} : acceptable overall temperature of the hottest spot
- Θ_a : the actual ambient temperature expected at -30 °C and 60 °C
- Θ_r : allowable temperature in the hottest place at rated current

Ex) The calculation of the applicable load current value when a breaker with rated current 2000A is used at 55 °C ambient temperature
 $I_a = 2000 \times ((105-55)/65)^{1/2} = 2000 \times 0.87 = 1754A$

Rated current (A)	Ambient temperature (°C)								
	20	25	30	35	40	45	50	55	60
3000	3000	3000	3000	3000	3000	2882	2760	2631	2496
2000	2000	2000	2000	2000	2000	1922	1840	1754	1664
1200	1200	1200	1200	1200	1200	1153	1104	1052	998

<Table 2> Allowable load current by ambient temperature

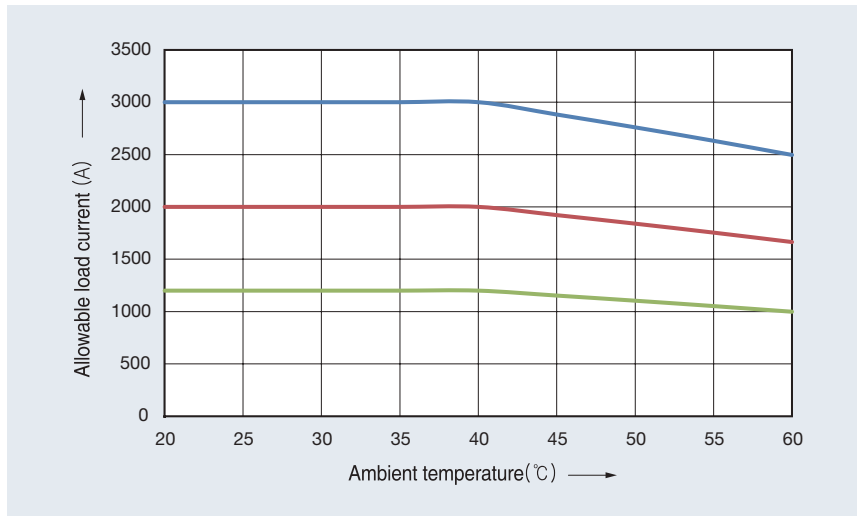

<Figure 3> Allowable load current by ambient temperature

Memo

Susol

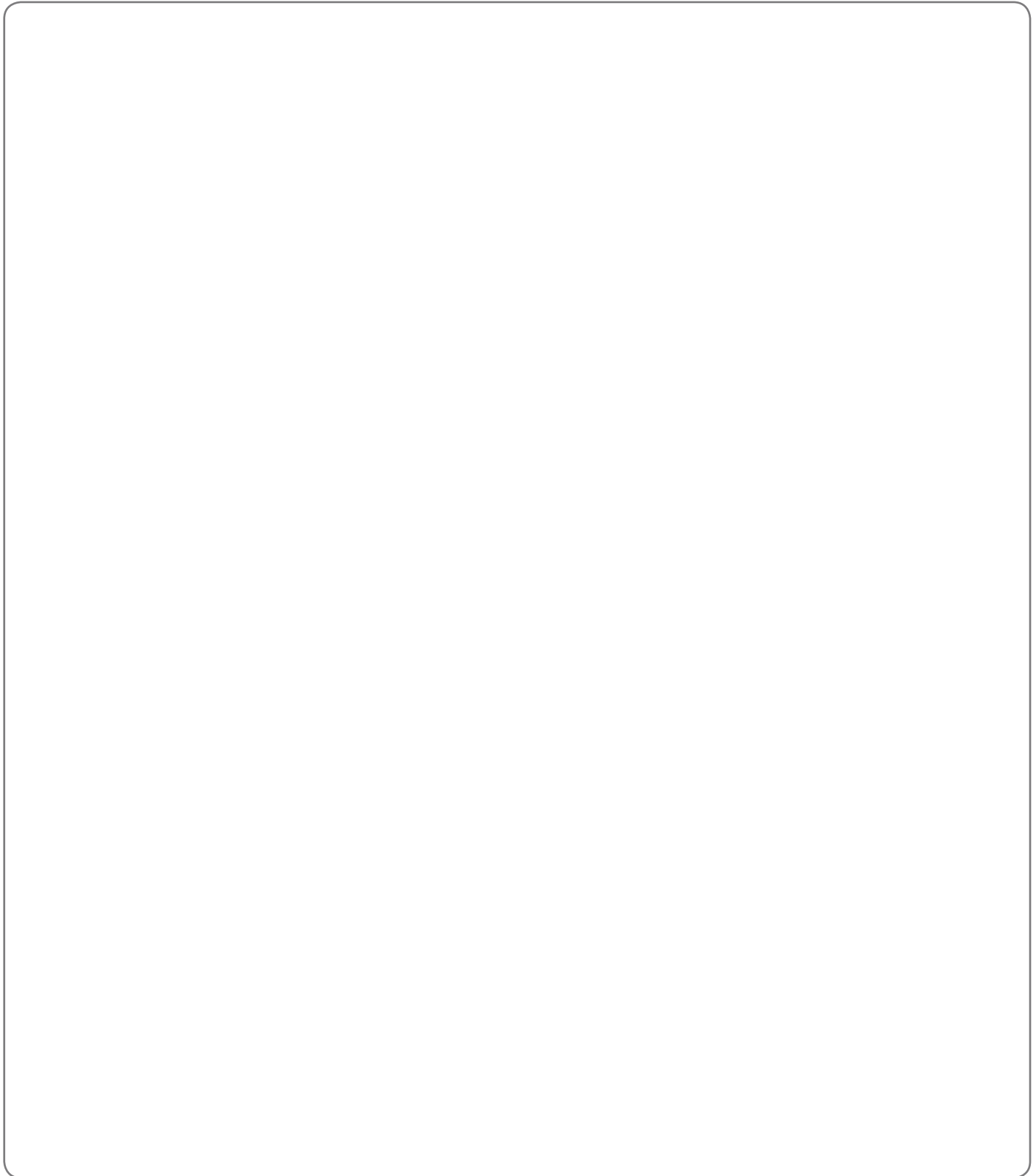

Memo

Susol

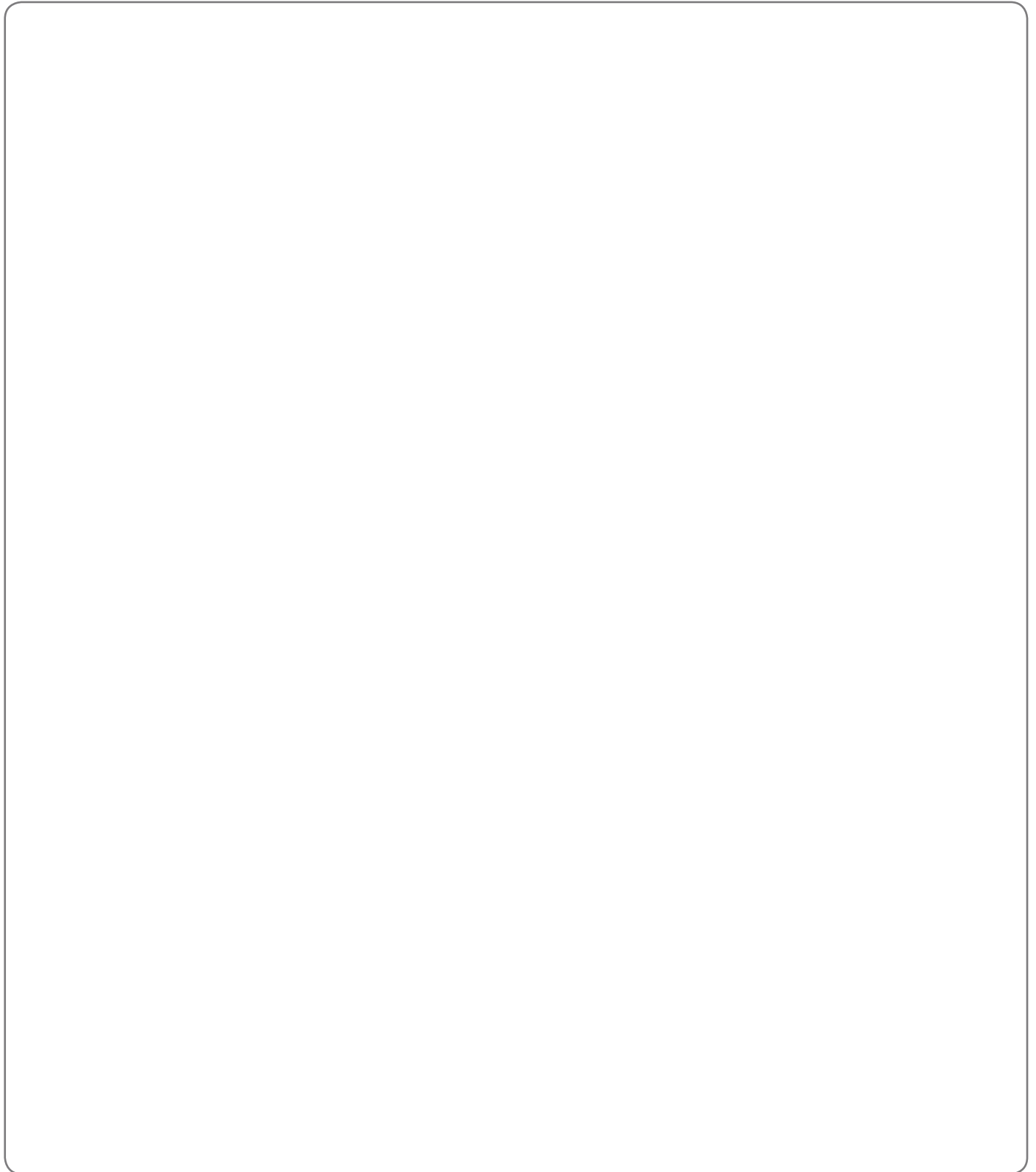

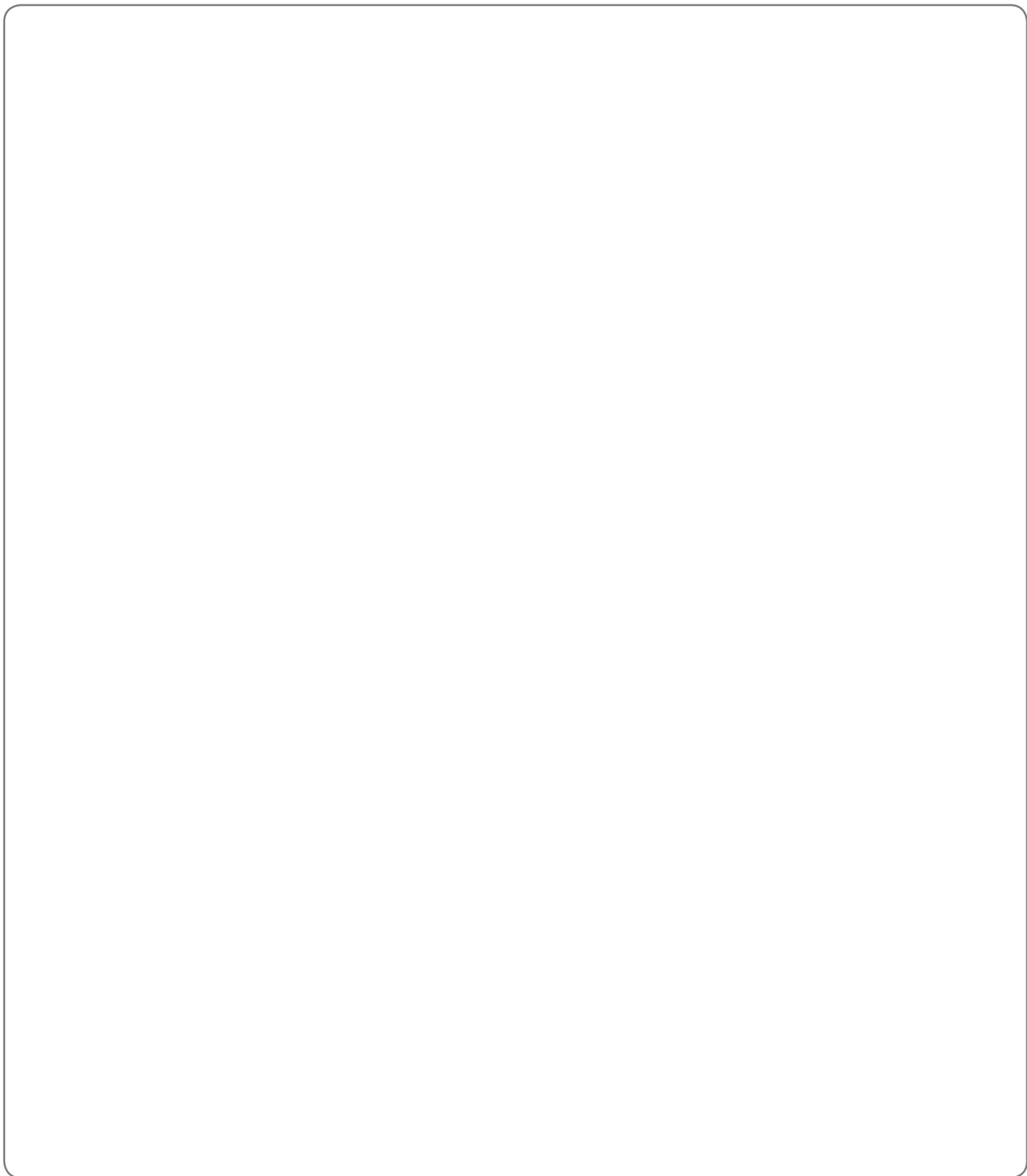



Safety Instructions

- For your safety, please read user's manual thoroughly before operating.
- Contact the nearest authorized service facility for examination, repair, or adjustment.
- Please contact qualified service technician when you need maintenance. Do not disassemble or repair by yourself!
- Any maintenance and inspection shall be performed by the personnel having expertise concerned.



www.lselectric.co.kr/USA

■ LS ELECTRIC America Inc. Chicago Head Office

980 Woodlands Parkway, Vernon Hills, IL 60061 USA
Tel: 1-800-891-2941 E-Mail: sales.us@lselectricamerica.com

■ Headquarter

127 LS-ro (Hogye-dong) Dongan-gu, Anyang-si, Gyeonggi-Do, 14119, Korea

■ Seoul Office

LS Yongsan Tower, 92, Hangang-daero, Yongsan-gu, Seoul, 04386, Korea
Tel. 82-2-2034-4916, 4684, 4429

■ Overseas Subsidiaries

- **LS ELECTRIC Japan Co., Ltd. (Tokyo, Japan)**
Tel: 81-3-6268-8241 E-Mail: jschuna@lselectric.biz
- **LS ELECTRIC (Dalian) Co., Ltd. (Dalian, China)**
Tel: 86-411-8730-5872 E-Mail: jiheo@lselectric.com.cn
- **LS ELECTRIC (Wuxi) Co., Ltd. (Wuxi, China)**
Tel: 86-510-6851-6666 E-Mail: jdym@lselectric.com.cn
- **LS ELECTRIC Vietnam Co., Ltd.**
Tel: 84-93-631-4099 E-Mail: jhchoi4@lselectric.biz (Hanoi)
Tel: 84-24-3823-7890 E-Mail: sjbaik@lselectric.biz (Hochiminh)
- **LS ELECTRIC Middle East FZE (Dubai, U.A.E.)**
Tel: 971-4-886-5360 E-Mail: hschoib@lselectric.biz
- **LS ELECTRIC Europe B.V. (Hoofddorf, Netherlands)**
Tel: 31-20-654-1424 E-Mail: europartner@lselectric.biz

■ Overseas Branches

- **LS ELECTRIC Tokyo Office (Japan)**
Tel: 81-3-6268-8241 E-Mail: jschuna@lselectric.biz
- **LS ELECTRIC Beijing Office (China)**
Tel: 86-10-5095-1631 E-Mail: chendm@lselectric.com.cn
- **LS ELECTRIC Shanghai Office (China)**
Tel: 86-21-5237-9977 E-Mail: khpaek@lselectric.com.cn
- **LS ELECTRIC Guangzhou Office (China)**
Tel: 86-20-3818-2883 E-Mail: chenxs@lselectric.com.cn
- **LS ELECTRIC Chengdu Office (China)**
Tel: 86-28-8670-3201 E-Mail: yangcf@lselectric.com.cn
- **LS ELECTRIC Qingdao Office (China)**
Tel: 86-532-8501-2065 E-Mail: wangzy@lselectric.com.cn
- **LS ELECTRIC Nanjing Office (China)**
Tel: 86-25-8467-0005 E-Mail: ylong@lselectric.com.cn
- **LS ELECTRIC Bangkok Office (Thailand)**
Tel: 66-90-950-9683 E-Mail: sjleet@lselectric.biz
- **LS ELECTRIC Jakarta Office (Indonesia)**
Tel: 62-21-2933-7614 E-Mail: dioh@lselectric.biz
- **LS ELECTRIC Moscow Office (Russia)**
Tel: 7-499-682-6130 E-Mail: jdpark1@lselectric.biz
- **LS ELECTRIC America Western Office (Irvine, USA)**
Tel: 1-949-333-3140 E-Mail: jwyun@lselectricamerica.com



Technical Question or After-sales Service

Customer Center-Quick Responsive Service, Excellent technical support

82-1644-5481